

MASSACHUSETTS INSTITUTE OF TECHNOLOGY
LINCOLN LABORATORY

A COCKPIT SITUATION DISPLAY
OF SELECTED NAS/ARTS DATA

R. W. BUSH

H. BLATT

Group 41

F. X. BRADY

Division 4

TECHNICAL NOTE 1970-39

15 DECEMBER 1970

This document has been approved for public release and sale;
its distribution is unlimited.

The work reported in this document was performed at Lincoln Laboratory, a center for research operated by Massachusetts Institute of Technology, with the support of the Department of the Air Force under Contract F19628-70-C-0230.

This report may be reproduced to satisfy needs of U.S. Government agencies.

ABSTRACT

By the mid-1970's, the evolving National Airspace System/Automatic Radar Control Terminal System (NAS/ARTS) ground environment will provide the air traffic controllers with high quality computer-processed traffic situation displays. We believe it would be useful, particularly in busy terminal areas, to display some of this data in the cockpit. Systems with this objective have been constructed and flight tested at least 3 times during the past 25 years, but these earlier systems could not benefit from: 1) a source of computer-processed data of the quality to be available from NAS/ARTS; 2) aircraft altitude information; 3) contemporary digital data link techniques; and 4) airborne equipment capable of automatically selecting and displaying only information relevant to a particular airplane. It is believed that an effective cockpit display would permit pilots, under IFR conditions, to retain some of the station-keeping and navigation functions they perform during VFR conditions and thereby improve the efficiency of terminal area operation.

The goals of the proposed program are: a) to evaluate the effectiveness of this class of system in reducing pilot and controller work loads, and b) to determine its potential for expediting traffic flow in busy terminal areas.

A simulated cockpit display has been developed and experienced pilots and controllers who have "flown" it have endorsed enthusiastically the desirability of evaluating this class of system in an operational environment.

Accepted for the Air Force
Joseph R. Waterman, Lt. Col., USAF
Chief, Lincoln Laboratory Project Office

Acknowledgement

The system discussed in this paper is currently being studied by members of the following MIT Laboratories: Lincoln Laboratory, Electronic Systems Laboratory, Flight Transportation Laboratory, and Man-Vehicle Laboratory. The latter three laboratories, located on the MIT Campus, are using a computer controlled simulator to model candidate displays and to evaluate the operational and human factors aspects of the system. The Electronic Systems and Man-Vehicle Laboratories are concerned with the cockpit display instrumentation and its effect on pilot workload; the Flight Transportation Laboratory is developing concepts for using the situation display in the enroute and terminal areas and is assessing the effects of these concepts in improving the traffic handling capacity of the ATC system. The Lincoln Laboratory is coordinating the work and investigating the feasibility of building an experimental system. The system design presented in this paper has evolved from the coordinated effort.

I. Introduction

The substantial reduction of terminal area traffic capacity under IFR conditions, in comparison with that routinely achieved during VFR, is one of the critical problems in air traffic control. A cockpit situation display system is proposed as a means for tightening the coupling between the pilot and the ground controller to effect a more efficient flow of traffic.

The pilot is an active participant in the air traffic control process under VFR conditions, even when he is operating on an IFR clearance. His ability to see the relative position of other aircraft, and his own position relative to the ground, permits operational flexibility which enhances both safety and terminal area traffic flow. When weather denies him the ability to see, the pilot must depend entirely on the air traffic controller for separation from other aircraft; the controller and pilot work loads become greater; and often these conditions result in an operationally induced increase in separation distances. Under current IFR procedures the controller, in essence, provides guidance as well as separation service to each aircraft. The net result of these factors is to make the traffic handling capacity of an airport lower under IFR conditions than it is under VFR conditions.

As the NAS/ARTS capability grows during the coming decade, accurate and reliable data on terminal area traffic will be available to the controllers. Providing some of this information to the pilot, together with relevant navigation data, should restore much of the information he uses under VFR conditions. Current technology will permit pertinent data on the NAS/ARTS controller's scope to be broadcast over a relatively low-rate data link operating in a VHF voice channel. Equipment in each aircraft would select and display only the air traffic and geographical information in its vicinity. Figure 1 is a sketch of one form of a cockpit presentation.

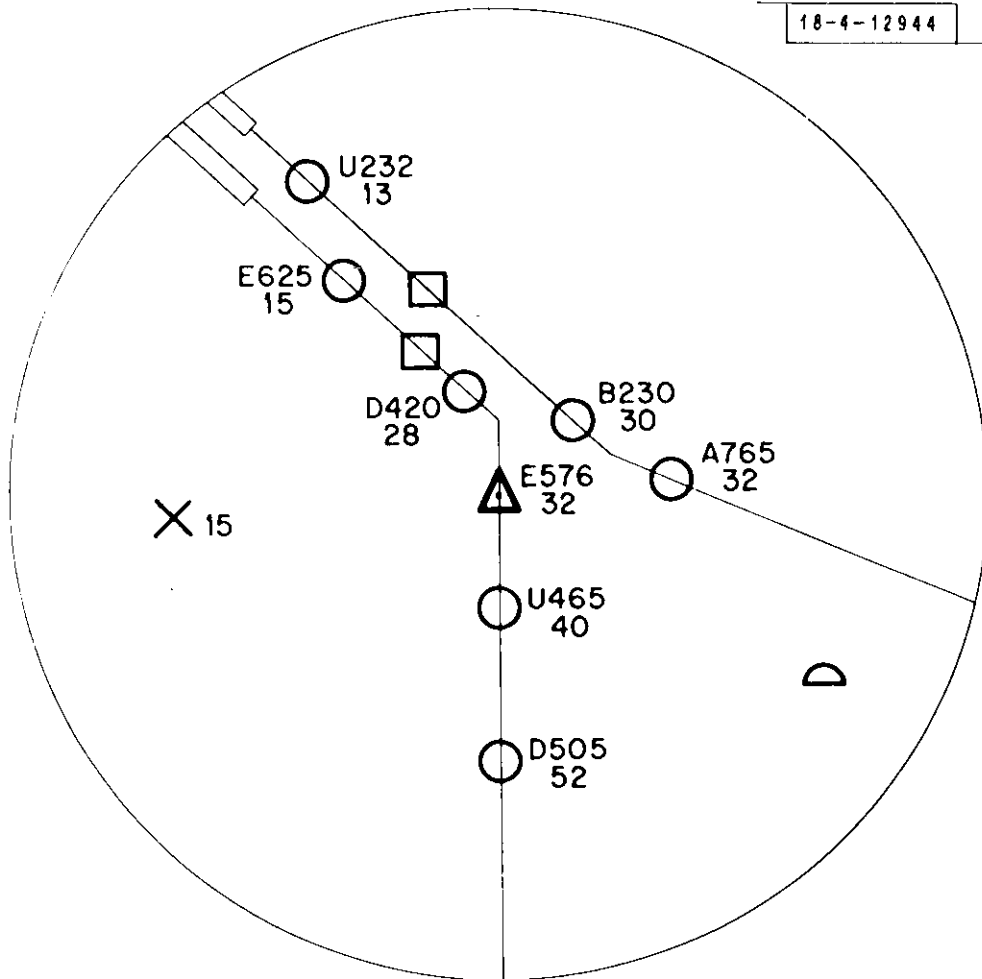

△ Own aircraft

○ Other identified aircraft

◐ Unidentified aircraft

□ Outer marker

× Obstruction

E576 Eastern 576 at
3200 ft. MSL

Fig. 1. Typical cockpit presentation (scale = 12-mile radius).

The concept of relaying ground radar information to the cockpit has been investigated by at least three* different groups at various times during the past 25 years. These earlier systems did not have: (1) clean computer-processed data on the ground (2) altitude information of the type to become available with Mode C beacons, (3) advanced digital data link techniques, and (4) airborne equipment capable of sorting and displaying only relevant information to the pilot.

As the ATC system evolves in the future, the proposed system could be expanded to handle additional tasks by relatively simple software changes in the ground and airborne computers. One new task might involve displaying automated sequencing and spacing data to the pilot by relaying the ARTS-generated time-to-turn commands directly to the aircraft. The controller would monitor the total situation display and the computer-generated commands and could edit or modify them as necessary. The proposed system is also compatible with a sequencing and spacing concept in which the pilot or autopilot would be directed to maneuver the aircraft to intercept and remain within a moving "bubble" displayed on his CRT. The position and velocity of the "bubble" would be controlled by the sequencing and flow algorithm of the computer equipment on the ground.

Another feature of the proposed system is that it provides information which could be used for area navigation. Map information and applicable air routes would be transmitted on the data link and this would assure that both controllers and pilots would be using common and current data. Only

*Among these are TELERAN-RCA, (1946); RATCA-USAF, (1963); and TELEVISED RADAR-FAA, (1966).

data appropriate for a particular phase of flight operation would be displayed.

The proposed system also provides information useful for collision avoidance. One desirable feature of this type of airborne collision avoidance system (CAS) would be the redundancy it would provide to back up calculations performed by NAS/ARTS. In addition it distributes the CAS computation task among the aircraft desiring protection, and no new equipment beyond that required for the ground surveillance system need be installed in small aircraft. Therefore, the system offers protection against all aircraft in a reasonable time period at a reasonable cost.

Because of the many interesting attributes of the proposed system, in May 1970, the MIT Lincoln Laboratory established a project to investigate the concept further. A system concept definition study has been completed and some of the results are reported in Section II. The preliminary design of an experimental system is presently under way. Lincoln Laboratory is collaborating with the Flight Transportation Laboratory, the Electronic System Laboratory, and the Man-Vehicle Laboratory on the MIT campus on operational research studies, display parameter definition, and the human factors aspects of the system. The campus groups have developed a computer-driven cockpit display simulator which permits a pilot to fly a 707-type aircraft within a typical terminal area. The goal of this simulation is to define the most appropriate modes and degree of flexibility needed in the display. Interesting experiments have been conducted which demonstrate the usefulness of this type of display for merging, station-keeping, flying in prescribed holding patterns and flying to remain within a dynamically controlled guidance "bubble". These experiments are scheduled to continue till mid-1971.

Figure 2 is a photograph of the initial simulation of the traffic situation display in operation showing the flight controls, a CRT presentation of the situation display, and a set of flight instruments. A more realistic cockpit simulator utilizing a surplus cockpit mock-up provided to MIT by the Boeing Aircraft Company will soon be in operation. This simulator will be used to define the display parameters and for human factor and pilot workload studies.

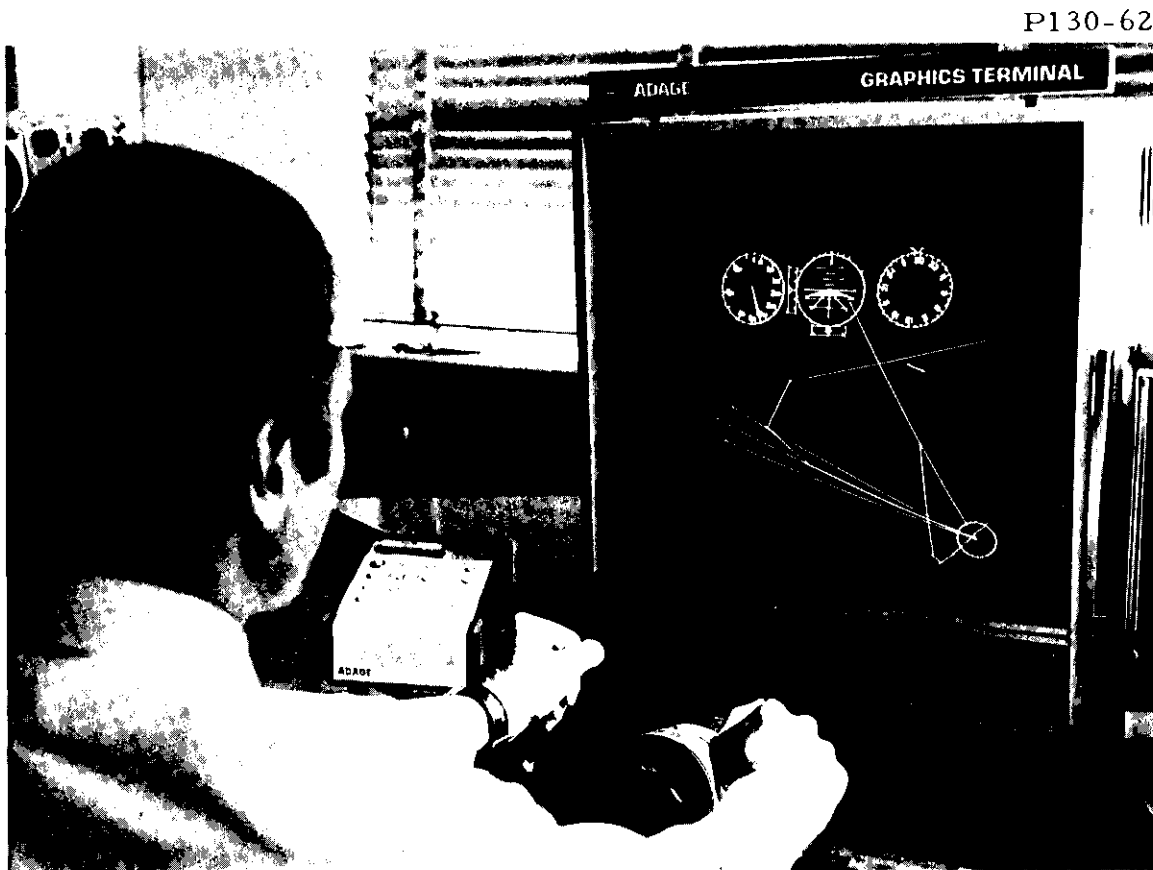

Fig. 2. Initial simulation of a situation display. The flight instruments appear on the cathode ray tube because it is more expedient for simulation purposes.

II. System Description

The proposed airborne traffic situation display system, described in the block diagram Fig. 3, contains three equipment groups: (1) the ARTS III components with which the proposed system will interface; (2) the ground-based equipment that will serve all aircraft, providing common information via a data link; and (3) the airborne equipment in each aircraft, including data link receiver, computer, and display facilities. Although an ARTS computer is shown in this diagram as the source of traffic data, NAS data could also be uplinked to the same airborne equipment. A small computer would provide a common message format.

In Fig. 3, the ARTS III equipment has been simplified to include only elements relevant to the proposed system, i. e., the computer containing the digital data base and the high speed multiplexor* which sends the data to both the controller displays and the proposed system.

Message Processing Computer

This computer is the ground-based component which interfaces the ARTS III system and the traffic display data link. Its function is to format digital data into a stream of messages suitable for transmission over the data link. The source of traffic data is the digital display data base of the ARTS III system. In initial versions of ARTS, this data will contain only information derived from beacon-equipped aircraft. Later versions of ARTS

*The nomenclature high speed multiplexor is consistent with original FAA specifications on ARTS III and also literature from Texas Instruments, the supplier of the display equipment. Literature from Univac, the supplier of the digital processing equipment, denotes the block in Fig. 3 by which the displays are refreshed as an I/O processor.

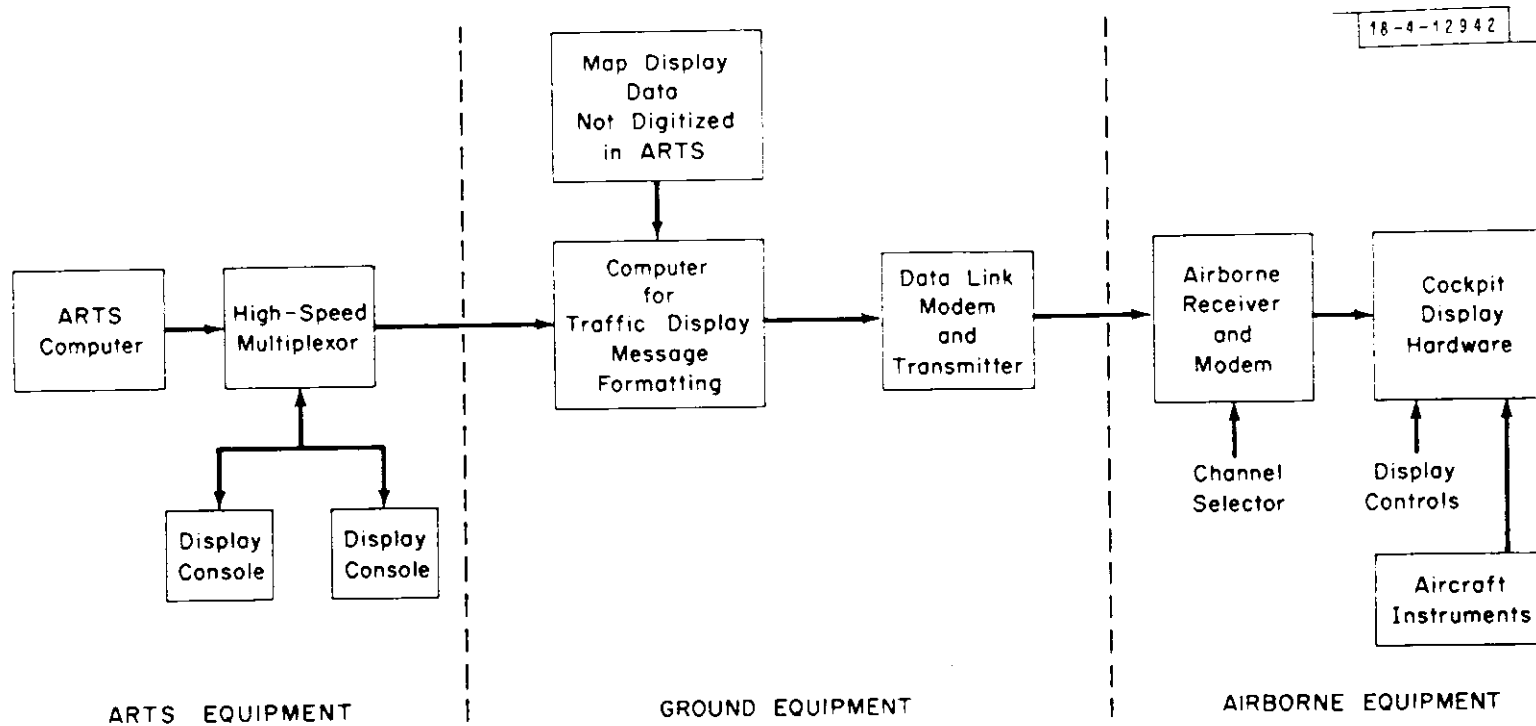

Fig. 3. Traffic display system block diagram.

will process primary radar data, will digitally display airway fixes, airways, control area boundaries and weather contours, and will generate and display suggested sequencing and spacing commands for the controllers. The map data source shown in Fig. 3 allows some of these advanced features as well as others such as three dimensional standard approach and departure routes to be included in an experimental version of the proposed traffic display system.

The controller displays in ARTS are refreshed by digital data transmitted over high-speed multiplexor ports, 24 to 30 times each second. A much slower refresh rate, such as once every 4 seconds (the radar data rate in the terminal area), is all that is required for the message processing computer of the proposed system; equipment on the airplane will re-establish an acceptable refresh rate after the data are received. An experimental evaluation of the proposed concept could be conducted without changing either the ARTS III software or hardware. The experimental system would access the ARTS III digital display data by means of parallel connections made to one or more of the multiplexor ports driving the controller displays. In a final version of the system, a multiplexor port would be dedicated to the message processing computer interface, and software would be introduced into the ARTS system to service this port. Such a modification would place an additional demand on the order of 1% on the ARTS equipment. The advantage of this approach over that proposed for an experimental system is that it minimizes the time delay associated with the traffic information reaching the cockpit.

Data Link

The data link consists of a transmitter and receiver as well as the modems required to interface with the ground and airborne computers. Studies indicate that the data required to service 100 aircraft in a terminal

environment could be handled at an 8K bit/second transmission rate, providing a complete traffic picture every four seconds; this data rate can be accommodated in a 25kHz VHF channel.

The messages transmitted over the data link will be of two types; one describing aircraft traffic, and the other map information (including weather contours when available). The messages will be grouped so that a complete traffic picture will be uplinked at a rate on the order of once every 4 seconds. This group of messages will be called a message frame.

The information contained in the aircraft traffic message associated with a particular aircraft will be the X, Y coordinates of the aircraft and some combination of the following: altitude; alphanumeric identification (ID); ground speed derived from computer tracking data; transponder identification and/or emergency indications; and in the future, additional information such as alphanumeric sequencing and spacing commands. The extent of the information on a particular aircraft will depend on whether it is transponder equipped and on whether it is being tracked by ARTS.

Each map message describes an item such as a point object (VORTAC, outer marker, etc.), a line object (runway, airway, restricted area, boundary, weather contour, standard approach and departure routes, ILS glide slope, etc.), or text (barometer setting, runway conditions, etc.). Uplinking map information insures that all aircraft and controllers have a common, current map and that the map is not cluttered with irrelevant data such as runways or approach and departure routes not in use at that time.

Airborne Equipment

The equipment on board the aircraft consists of the data link receiver and modem, a small digital processor and display hardware. A directional

gyro on the aircraft supplies heading data to this equipment.

When the airborne equipment is initially turned on, the processor is ignorant* of the position of the aircraft, but does know its ID. Position is determined by searching the first available message frame for the traffic message associated with the aircraft. This message is easily detected by examining the ID codes. Once the processor knows the position of the aircraft, it can select from subsequent message frames the relevant traffic and map information. Traffic messages are examined to see which aircraft are within a specified volume surrounding the aircraft. The messages associated with these aircraft are stored within the computer. Map data are also stored in the computer if they refer to the geographic area surrounding the aircraft. The computer and display equipment then use this data to generate and refresh a display in the cockpit.

On-Board Display Hardware Options

A number of options exist for the choice of the on-board equipment which reflect greater or lesser capability and cost. The systems outlined below include: (1) an experimental system, (2) a system for airliners and (3) a system for the larger general aviation aircraft. Numerous intermediate options are possible, all using the same uplinked data.

System 1 - Experimental Version (Fig. 4)

The principal subsystems are a small processor, a line and symbol generator, hardware to rotate the displayed picture, and the indicator

*If the computer is shared by other functions in the aircraft or has access to other sensor data, the aircraft position may be known. The traffic display system is designed as an independent source of navigational and traffic information and, therefore, is not dependent on such information.

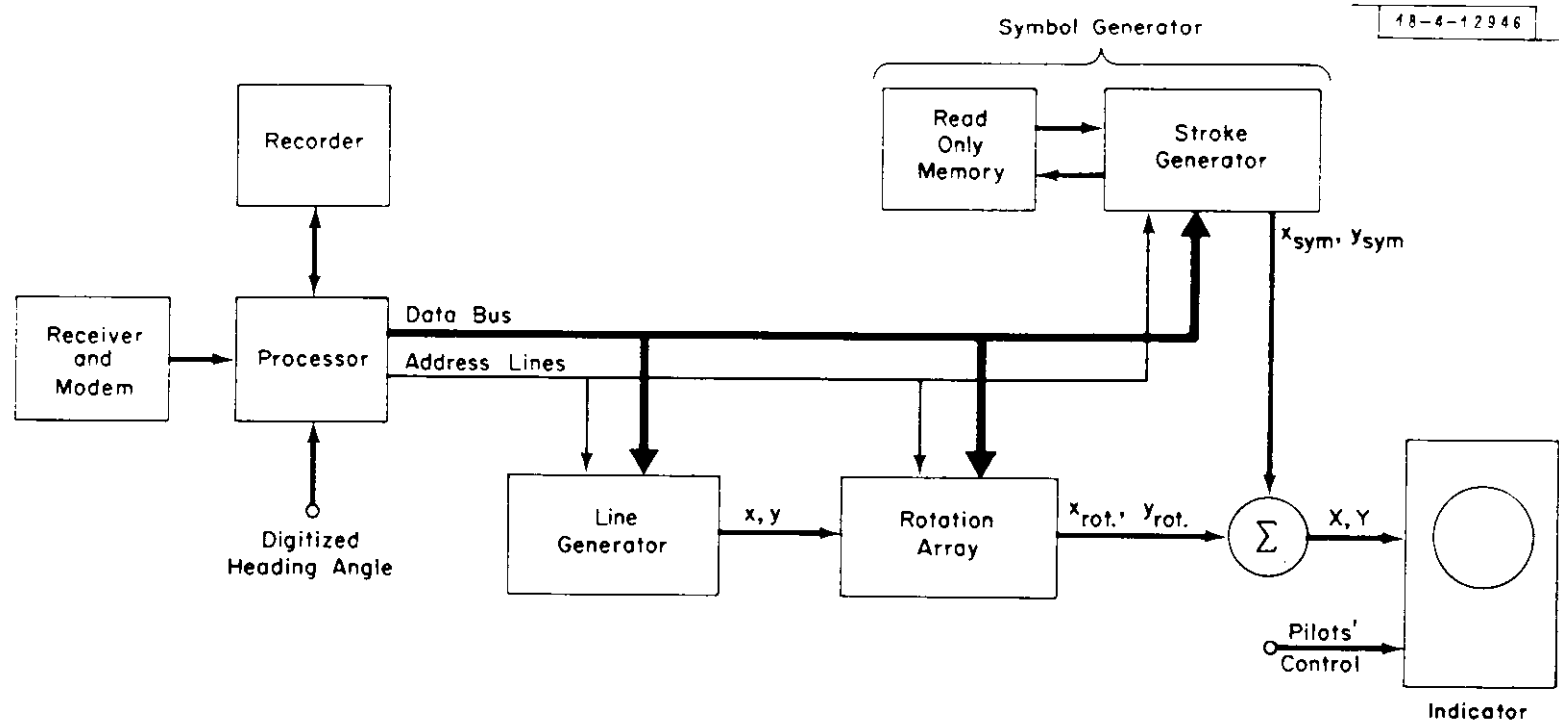

Fig. 4. Cockpit display hardware - experimental system.

including the CRT and its associated driving and power circuitry. Display modes are selected by the pilot via a display control panel.

The processor selects from the incoming stream of uplinked data only those pieces of traffic and map information which are relevant to that aircraft and ignores the rest. With the relevant data it constructs a display file which is read out at the display refresh rate to the line and symbol generators. The line generator is used to draw such items as airways, runways, weather contours and outlines of restricted areas; the symbol generator is used for drawing both alphanumerics and special characters representing, for example, VOR's and obstructions.

The output of the line generator drives an array of multiplying D/A converters. If the pilot chooses an aircraft centered, heading oriented presentation then the array performs the required angle transformation. Digital heading data are supplied to the array from on-board instruments and are routed to the array via the processor.

This experimental system is the most flexible of the proposed systems, the processor having sufficient computing and storage capacity to permit various options to be evaluated and system parameters to be optimized under actual flying conditions. Of particular interest are the determination of: the optimum range of display scales, display data update rate and method, and the feasibility of on-board target tracking. Recording equipment will be connected to the processor to allow monitoring of system operation.

System 2 - Airline Version

This display is similar to the experimental system but without its additional computing and storage capacity or recorder capability. The operational features included will depend on the experience gained during

flight tests of the experimental system. The processor and indicator need not be dedicated to the traffic display but could be integrated into the aircraft's processor and display complement.

System 3 - General Aviation Version (Fig. 5.)

This is a low cost version of the display, within the price range of general aviation operators. It uses the same uplinked data as the airliner version; however, map information is not shown and the display scale is fixed. The display is aircraft centered and heading oriented. Heading is derived from the aircraft directional gyro. Each target will be displayed as a three digit number representing the target's altitude; the position of the number on the display indicates the target location.

The processor for this system is a very small special purpose serial computer with a serial memory. The computer sorts the incoming data and selects only relevant target data. It also performs the manipulations required on the data to produce an aircraft-centered display file. Display data in the serial memory are recirculated at the refresh rate. The symbol generator produces alphanumerics only, and character blocks are positioned by D/A converters; there is no line generator. Rotation is accomplished by an array of analog multipliers.

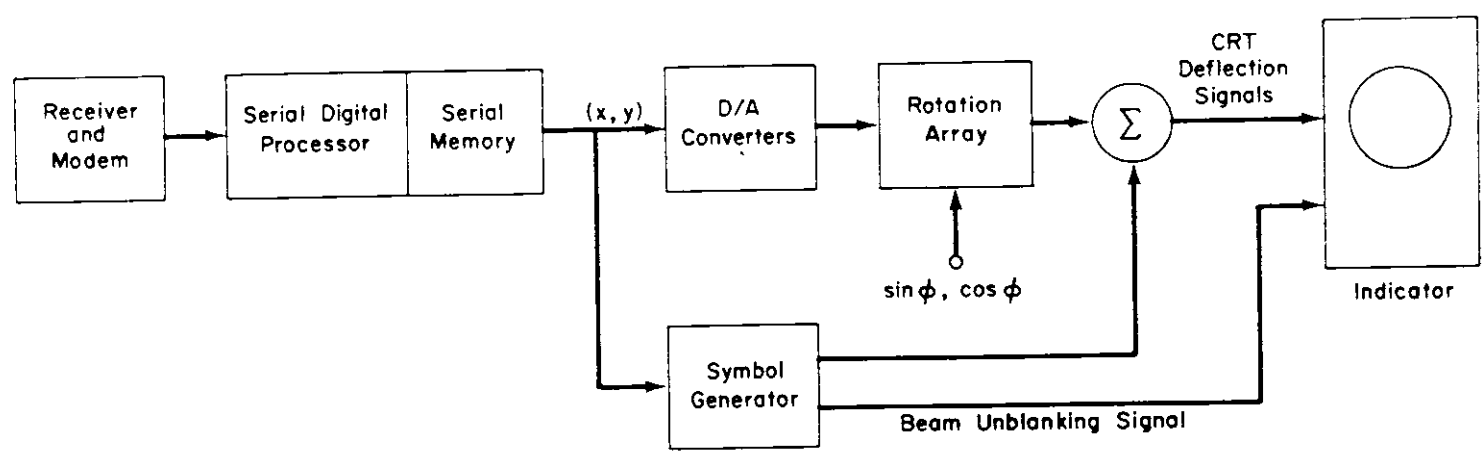

Fig. 5. Cockpit display hardware - low cost system.

III. Summary

An air traffic situation display system is described which will provide pilots with significantly more information on their environment than they currently have during IFR conditions, and which will be a useful supplement to vision even during VFR conditions. Appropriate information from NAS/ARTS would be uplinked from the ground in digital form and a small on-board computer would select and display traffic and map data in a format centered on the user's aircraft. Such a display should provide pilots with information that would enable them to fly and navigate with respect to other traffic and reference fixes. This feature could enhance terminal area capacity during IFR conditions.

The information the proposed system provides in the cockpit could also be useful for area navigation and collision avoidance. For these applications, the equipment ultimately would be integrated with other airborne equipment. The proposed system also supports and augments the automatic sequencing and spacing features being considered for the more highly automated NAS/ARTS system.

Since the source of the data for this system is the already planned NAS/ARTS system and since the transmission of this data to aircraft requires little additional investment in ground equipment, this new capability can be added at low cost.

Relatively simple airborne equipment for the proposed system can be built at a price acceptable to general aviation users; higher cost, more versatile equipments would be used by commercial airliners. Both types use the same uplinked data base. As improvements to the ground equipment provide the controllers with a better picture of the air environment, these improvements will be available in the cockpit without requiring a change in the airborne equipment. In principle, the airport ground traffic could be displayed whenever ASDE or similar data is available by sending this information on a separate VHF channel.

The ultimate impact of the proposed system on the evolution of the ATC system is difficult to forecast and should be evaluated through simulation and by field trials in a NAS/ARTS environment.

DOCUMENT CONTROL DATA - R&D		
<i>(Security classification of title, body of abstract and indexing annotation must be entered when the overall report is classified)</i>		
1. ORIGINATING ACTIVITY (Corporate author) Lincoln Laboratory, M. I. T.	2a. REPORT SECURITY CLASSIFICATION Unclassified	2b. GROUP None
3. REPORT TITLE A Cockpit Situation Display of Selected NAS/ARTS Data		
4. DESCRIPTIVE NOTES (Type of report and inclusive dates) Technical Note		
5. AUTHOR(S) (Last name, first name, initial) Bush, Richard W. Blatt, Howard Brady, Francis X.		
6. REPORT DATE 15 December 1970	7a. TOTAL NO. OF PAGES 22	7b. NO. OF REFS None
8a. CONTRACT OR GRANT NO. FJ9628-70-C-0230	9a. ORIGINATOR'S REPORT NUMBER(S) Technical Note 1970-39	
b. PROJECT NO. 649L	9b. OTHER REPORT NO(S) (Any other numbers that may be assigned this report) ESD-TR-70-404	
c.		
d.		
10. AVAILABILITY/LIMITATION NOTICES This document has been approved for public release and sale; its distribution is unlimited.		
11. SUPPLEMENTARY NOTES None	12. SPONSORING MILITARY ACTIVITY Air Force Systems Command, USAF	
13. ABSTRACT <p>By the mid-1970's, the evolving NAS/ARTS ground environment will provide the air traffic controllers with high quality computer-processed traffic situation displays. We believe it would be useful, particularly in busy terminal areas, to display some of this data in the cockpit. Systems with this objective have been constructed and flight tested at least 3 times during the past 25 years, but these earlier systems could not benefit from: 1) a source of computer-processed data of the quality to be available from NAS/ARTS; 2) aircraft altitude information; 3) contemporary digital data link techniques; and 4) airborne equipment capable of automatically selecting and displaying only information relevant to a particular airplane. It is believed that an effective cockpit display would permit pilots, under IFR conditions, to retain some of the station-keeping and navigation functions they perform during VFR conditions and thereby improve the efficiency of terminal area operation.</p> <p>The goals of the proposed program are: a) to evaluate the effectiveness of this class of system in reducing pilot and controller work loads, and b) to determine its potential for expediting traffic flow in busy terminal areas.</p> <p>A simulated cockpit display has been developed and experienced pilots and controllers who have "flown" it have endorsed enthusiastically the desirability of evaluating this class of system in an operational environment.</p>		
14. KEY WORDS air traffic control collision avoidance situation displays human factors		