

© Copyright 2002 American Meteorological Society (AMS). Permission to use figures, tables, and brief excerpts from this work in scientific and educational works is hereby granted provided that the source is acknowledged. Any use of material in this work that is determined to be “fair use” under Section 107 of the U.S. Copyright Act or that satisfies the conditions specified in Section 108 of the U.S. Copyright Act (17 USC §108, as revised by P.L. 94-553) does not require the AMS’s permission. Republication, systematic reproduction, posting in electronic form on servers, or other uses of this material, except as exempted by the above statement, requires written permission or a license from the AMS. Additional details are provided in the AMS CopyrightPolicy, available on the AMS Web site located at (<http://www.ametsoc.org/AMS>) or from the AMS at 617-227-2425 or [copyright@ametsoc.org](mailto:copyright@ametsoc.org).

Permission to place a copy of this work on this server has been provided by the AMS. The AMS does not guarantee that the copy provided here is an accurate copy of the published work.

## 1.9 ENHANCEMENTS TO TERMINAL DOPPLER WEATHER RADAR TO IMPROVE AVIATION WEATHER SERVICES

Gabriel R. Elkin\*, Oliver J. Newell, Mark E. Weber  
MIT Lincoln Laboratory, Lexington, Massachusetts

### 1. INTRODUCTION†

The Terminal Doppler Weather Radar (TDWR) has been deployed to 45 major U.S. airports to provide wind shear detection services and precipitation reflectivity data to controllers and supervisors. In addition, this sensor's characteristics make it well suited for additional applications. Its narrow beam and aggressive ground clutter suppression algorithms provide excellent data on boundary layer reflectivity and winds – in particular the locations of thunderstorm outflow boundaries. These data are known to be essential for providing high-resolution convective weather forecasts out to two hours. Similarly, its narrow beam could be useful for detection of severe weather signatures (e.g., tornado vortices) with small azimuth extent. Relative to the Weather Service Radar 88-D (NEXRAD) it scans rapidly (e.g., surface updates once per minute), facilitating monitoring of rapidly evolving low altitude wind shear hazards. It is typically located near to population centers and congested airspace, so that it is well situated for supporting weather services for operationally important areas.

This paper describes work underway to enhance the TDWR's capability to provide wind shear detection services in challenging conditions, and to improve the sensor's ability to support applications such as those described above. A Radar Data Acquisition (RDA) system retrofit will upgrade the transmitter, receiver and digital signal processing (DSP) subsystems of the radar to improve the quality of the reflectivity and Doppler imagery generated by the system and to extend its instrumented range. Key objectives include improved rejection of ground clutter and range-folded weather echoes, and better handling of high-wind conditions where Doppler aliasing may occur. The flexible radar "front-end" architecture could, in principle, support other enhancements such as generation of additional base-data fields (e.g., spectrum width) and polarimetric and/or multi-frequency measurements.

†This work was sponsored by the Federal Aviation Administration under Air Force Contract No. F19628-00-C-0002. The views expressed are those of the authors and do not reflect the official policy or position of the U.S. Government. Opinions, interpretations, conclusions, and recommendations are those of the authors and are not necessarily endorsed by the U.S. Government.

\*Corresponding author address: Gabriel Elkin, MIT Lincoln Laboratory, 244 Wood Street, Lexington, MA 02420-9108; e-mail: gabee@ll.mit.edu

### 2. ALGORITHMIC ENHANCEMENTS

Advances in computer hardware provide an opportunity to implement algorithm enhancements that will improve TDWR wind shear detection performance and support other aviation weather services. The near-term focus is improvement of base data quality via improvements to rejection of second trip weather, mitigation of Doppler velocity folding, and suppression of clutter. A study conducted at the Lincoln Laboratory Integrated Terminal Weather System (ITWS) test site in Memphis, Tennessee during 2000-2001 showed that these were the most frequent causes for significant TDWR data quality problems.

#### 2.1 RANGE FOLDING

Range-folding of weather echoes from beyond the maximum unambiguous range can be a significant problem. Currently, the TDWR employs a data editing scheme. A long pulse repetition time (PRT) "truthing" scan is made periodically at a low elevation angle to find weather echoes beyond the range limit. A constant PRT is then selected that ensures that range-folded echoes do not obscure the runway arenas. Range gates that contain range-folded echoes are then edited, resulting in the loss of weather data. Figure 1 provides an example in which range-folded weather echoes caused a gust front thin-line velocity signature to be obscured.

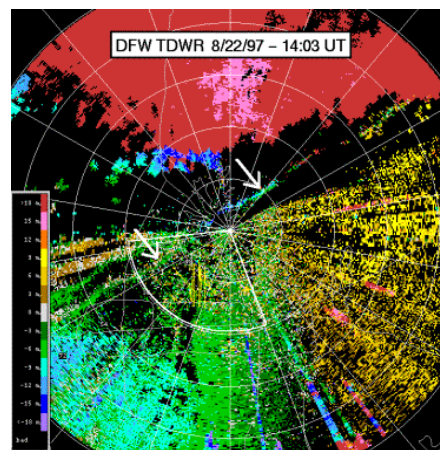

Figure 1. Gust front obscuration caused by range-folded weather echoes.

The range-folding problem can be addressed by pulse phase coding, a technique that assigns a known phase identity to each transmitted pulse (Laird 1981, Siggia 1983, Zrnic and Mahapatra 1985, Sachidananda and Zrnic 1986, Sachidananda and Zrnic 1999). The

phase code for each pulse is stored with the received signals, so that DSP algorithms can be used to remove the range-folded echoes from the coverage region. Shown in Figure 2, the phase code of the current and previous pulses are used to selectively cohere to either the first-trip or second-trip by rotating the received signal vectors appropriately. The figure depicts first-trip and second-trip weather echoes with different Doppler velocities. When the signal is coherent for the first trip, the second-trip weather echo appears as elevated white noise that can be strong enough to obscure the first-trip signal in some cases. Likewise, when the signal is coherent for the second trip, the first-trip signal appears as white noise. The second-trip data is then removed in the frequency domain using an adaptive whitening filter. Re-cohering for the first trip yields a recovered first-trip weather signal with improved signal-to-noise. The phase code processing technique is reversible, so that it is also possible to reject the first-trip and recover the second-trip signal, thereby effectively doubling the unambiguous range of the radar.

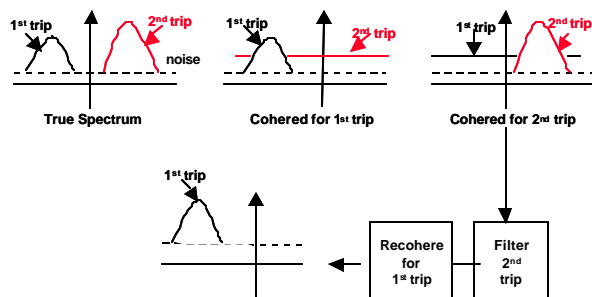

Figure 2. Pulse phase coding to reject out-of-trip range-folded weather and recover the first trip.

## 2.2 VELOCITY FOLDING

For weather events accompanied by high-wind conditions, the Doppler velocity of the signal may exceed the Nyquist velocity corresponding to the PRF in use. When this occurs, the resulting computed velocity is folded or aliased around the Nyquist velocity.

Currently, TDWR attempts to address velocity folding in the Radar Product Generator (RPG) using spatial continuity and wind-field modeling. This approach is subject to error in complex weather situations. It is well known that a more robust technique can be implemented in the DSP by using a multiple-PRT waveform (Zrnic and Mahapatra, 1985, Sachidananda and Zrnic, 2000). The waveform under investigation in this study uses a block-staggered pattern of two PRT's in a 2:3 ratio. If the PRTs are labeled  $T_1$  and  $T_2$ , the unambiguous velocity can be extended to:

$$v_a = \pm \lambda/4(T_1 - T_2),$$

For a 2:3 PRT ratio, this corresponds to a doubling of the unambiguous velocity compared with the shorter of the two PRTs.

The difficulty is that the measurement error variance in the "difference PRT" velocity estimate is twice that of the individual PRTs. The technique under

investigation addresses this problem by computing velocity as a weighted average of the more accurate individual PRT velocity estimates. The difference PRT velocity estimate is used only to properly unfold the individual PRT velocity estimates before averaging them. The averaging weights applied are proportional to the number of pulses transmitted at each PRT. Figure 3 shows a simulation of this velocity de-aliasing technique using simulated weather echoes with velocities between  $-50$  and  $+50$  m/s, for spectrum widths up to 4 m/s. A technique for clutter filter design for multiple-PRT waveforms is described by Chornoboy, 1993.

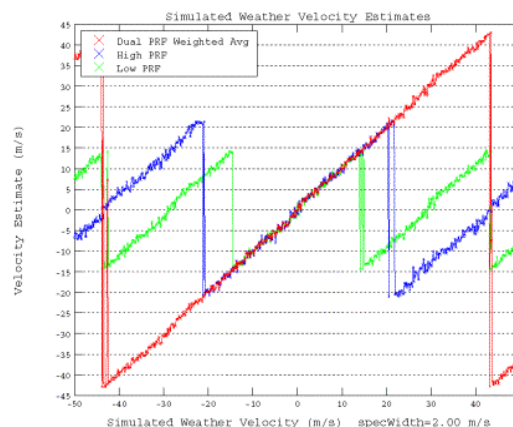

Figure 3. Demonstration of velocity de-aliasing algorithm using multiple-PRT waveform on simulated weather echoes.

## 2.3 SIMULTANEOUS RANGE AND VELOCITY UNFOLDING

The range and velocity unfolding techniques described above can be combined by applying pulse phase coding to a multiple-PRT waveform. Filtering of out-of-trip weather requires the use of discrete Fourier transforms (DFT's). A method for applying DFT's across a multiple-PRT waveform is described in Weber and Chornoboy, 1993.

A more straightforward dual-PRT technique was developed by SIGMET, Inc. as part of their RVP7 Doppler Signal Processor release 3.22. The approach employs two PRTs, and alternates between them on successive radials. The out-of-trip weather rejection and recovery algorithm described above is applied to a constant PRT within each radial. Velocity de-aliasing is then performed using the velocity estimate from the other PRT on the previous radial. An assumption is made that weather velocity does not change radically from one radial to the next, so that data from successive radials can be compared.

## 2.4 GROUND CLUTTER SUPPRESSION

TDWR utilizes a finite-impulse response (FIR) high-pass filter to suppress zero-velocity ground clutter by approximately 50 dB. Clutter residue may remain at the output of the filter, either because it has high reflectivity, or because its velocity is not sufficiently close to zero. Moving clutter due to birds or roads falls into the latter

category. TDWR provides a clutter residue editing map (CREM), created using data sampled on a clear day, to censor stationary ground clutter residue. At sites where the CREM does not provide sufficient suppression of clutter, clutter polygons are established that are used to aggressively censor affected range gates. This labor-intensive process is difficult to perfect, and can result in missed wind shear detections.

The problem of over-suppression imposed by static clutter editing maps can be addressed by an adaptive clutter filtering approach similar to what is used in the ASR-9 Weather Systems Processor (WSP) (Weber and Stone, 1995). The single high-pass FIR filter is replaced by a bank of FIR filters providing different levels of clutter suppression. For stationary ground clutter, the amount of suppression chosen depends on clutter residue maps that are created on a clear day and the intensity of the atmospheric returns. We are investigating various adaptive approaches to suppression of stationary and moving clutter.

The expansible processing architecture described in section 3 of this paper could support other algorithm enhancements.

### 3. TDWR RDA RETROFIT ARCHITECTURE

The TDWR system was designed and built in the late 1980's, and is encountering issues related to parts obsolescence. To ensure that the system continues to be maintainable, the FAA has commenced a Service Life Extension Program (SLEP) to improve supportability and, where appropriate, introduce improved capability.

A simplified block diagram of the TDWR is shown in Figure 4. The RPG subsystem, shown in the upper left, has recently been re-hosted from a Harris Nighthawk UNIX system to one based on a pair of redundant SGI Origin computers. The next major digital subsystem to be addressed, and the focus of this paper, is the RDA, which includes the receiver and DSP subsystems.

The existing TDWR DSP subsystem hardware consists of a mixture of COTS and custom cards, installed in a single 19" Multibus system chassis. The COTS boards include a 68020-based single-board computer (SBC), and a SCSI and serial controller. The custom components include five boards to handle the A/D interface and timing needs, eight boards to perform clutter filtering, and six boards to handle the generation of moments data.

The need to update the DSP subsystem is driven by a number of factors. The Multibus is no longer well supported, resulting in a lack of vendor support for the COTS processing elements in the subsystem. Though most of the custom boards have been reliable in the field, a number of the chips on the boards are no longer available. It is anticipated that by the 2005 timeframe, maintenance of the subsystem as it now stands will become difficult at best. In addition, the current hardware implementation of the signal processing algorithms prevents relatively simple algorithm changes

such as those described in this paper from being inserted into the sensor to improve wind shear detection performance in the field. The move to a modern architecture will both solve the maintenance issues and provide a means for insertion of new algorithms to solve real-world data quality problems.

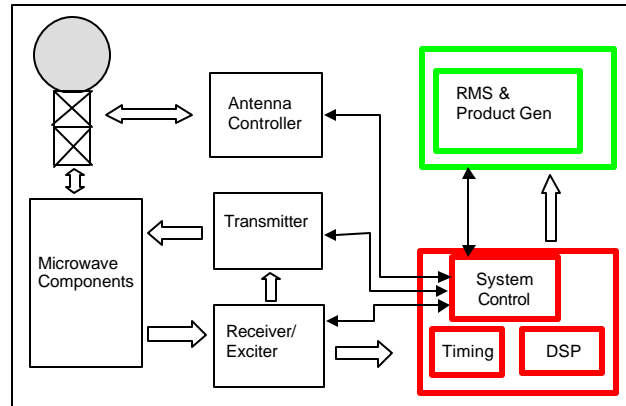

Figure 4. Legacy System Block Diagram

A conceptual block diagram for the re-hosted DSP subsystem is shown in Figure 5. The initial prototype will be based on the VME bus and high-speed RACE++ interconnect fabric, both well-established standards in the high-end DSP application space. The three COTS boards in the original design have been replaced by a single card with onboard support for multiple serial interfaces, SCSI, and 100 Base-T Ethernet. Note that the moments data computed by the DSP will be output via the 100 Base-T Ethernet in the new system, as opposed to using the SCSI interface as in the original implementation. The Ethernet approach is more flexible, since multiple users and diagnostic programs can simply attach to the Ethernet and 'tap in' to the moments data since it is broadcast using the UDP protocol.

The three hard-wired timing boards have been replaced by a single, 'generic' timing board hosting a set of large FPGA's and numerous I/O pins. This board is programmable at system startup via the VME bus, allowing it to be easily adapted to handle any future system modifications, such as the implementation of a pulse-to-pulse micro-stagger to reduce interference due to second-trip echoes.

The existing IF receiver, A/D's, and A/D interface cards are replaced by a single multi-channel digital receiver. This 14-bit digital receiver is capable of sample rates of up to 80 MHz, has a dynamic range in excess of 90 dB, and outputs I&Q data directly to the RACE++ interconnect. In addition, an on-board FPGA can be used to customize the board as necessary to tag the outgoing I&Q data stream with radar timing signals.

The core DSP processing elements are quad PowerPC 7400 processors from Mercury Computer Systems, nominally operating at 400 MHz. The PowerPC AltiVec technology allows for four multiply-accumulate operations to occur in parallel, for a peak

theoretical rating of 3.2 Gflops per CPU. Due to memory and cache issues when executing the TDWR algorithms, the expected sustained computational throughput is 800 Mflops per CPU. Since the original hard-wired DSP possessed on the order of 250 Mflops of processing power. A single quad PowerPC card possesses an order of magnitude more compute power than the original system. The prototype will be expandable to up to six quad-processor boards, providing on the order of 18 Gflops of compute bandwidth. Algorithms will be implemented using the VSIPL standard vector processing library, thereby easing any future porting effort to DSP boards from other manufacturers.

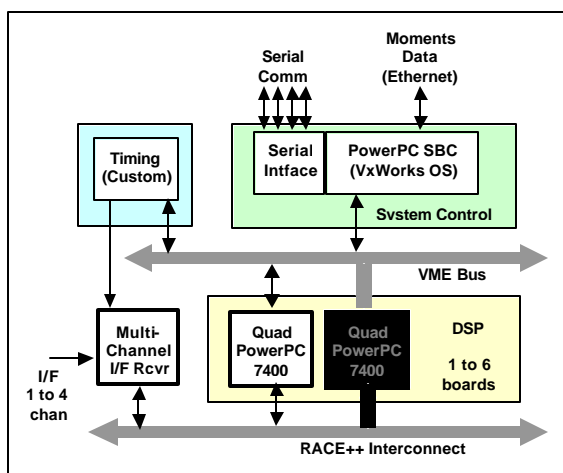

Figure 5. Re-hosted DSP Subsystem.

The prototype is tentatively scheduled to be tested starting in the summer of 2003. The goal of the test is to demonstrate that the existing capability of the TDWR has been successfully re-implemented, and the system design provides a solid platform for addition of new signal processing algorithms. Following the test and evaluation phase, a technology refresh will optionally be pursued prior to moving to full-scale production. In particular, the choice of bus and architecture will be reviewed to determine if upcoming serial interconnect technologies such as Infiniband and RapidIO have matured to the point where a technology refresh could be pursued in the desired timeframe at relatively low risk. The use of open systems hardware and software standards should make the migration relatively straightforward.

#### 4. SYSTEM DEVELOPMENT ACTIVITIES

In 2002, a proof-of-concept prototype is under development that will be deployed on a TDWR system at the FAA's Program Support Facility (PSF) in Oklahoma City. The goals of this effort are (1) to record time-series data from a TDWR system during the convective weather season, and (2) to demonstrate enhanced base data (i.e., reflectivity and velocity). As noted, in 2003 a second-generation prototype using the architecture described in Section 3 will be deployed at an operational TDWR site.

#### 5. SUMMARY

This paper has described work underway to enhance the TDWR's capability to provide wind shear detection services in challenging conditions, and to provide a flexible platform with COTS hardware that would support future improvements. A Radar Data Acquisition (RDA) system retrofit will upgrade the transmitter, receiver and digital signal processing subsystems of the radar to improve the quality of the reflectivity and Doppler imagery generated by the system and to extend its instrumented range. Algorithms have been described for achieving improved rejection of ground clutter and range-folded weather echoes, and reduction of Doppler velocity aliasing. An open COTS-based processing architecture was presented for the TDWR RDA retrofit, and a test program was outlined that is commencing in Oklahoma in the spring of 2002.

#### 6. REFERENCES:

- Chornoboy, E.S., 1993: Clutter Filter Design For Multiple-PRT Signals. Preprints, 26<sup>th</sup> Conference on Radar Meteorology, Amer. Met. Soc., Normal, OK, pp. 235-237.
- Chornoboy, E.S., 1994: Optimum Time-Varying FIR Filter Designs for the Airport Surveillance Radar Wind Shear Processor. MIT Lincoln Laboratory Project Report ATC-191.
- Laird, B.G., 1981: On Ambiguity Resolution by Random Phase Processing. Preprints, 20<sup>th</sup> Conference on Radar Meteorology, Boston, MA, American Meteorological Society, pp. 327-331.
- Newell, O., 2000: ASR-9 Weather Systems Processor Software Overview. MIT Lincoln Laboratory Project Report ATC-264.
- Sachidananda, M., Zrnica, D.S., 1986: Recovery of Spectral Moments from Overlaid Echoes in a Doppler Weather Radar. IEEE Transactions on Geoscience and Remote Sensing, Volume GE-24, No. 5, pp. 751-764.
- Sachidananda, M., Zrnica, D.S., 1999: Systematic Phase Codes for Resolving Range Overlaid Signals in a Doppler Weather Radar. Journal of Atmospheric and Oceanic Technology, Volume 16, pp. 1351-1363.
- Sachidananda, M., Zrnica, D.S., 2000: Clutter Filtering and Spectral Moment Estimation for Doppler Weather Radars Using Staggered Pulse Repetition Time (PRT). Journal of Atmospheric and Oceanic Technology, Volume 17, pp. 323-331.
- Siggia, A., 1983: Processing Phase-Coded Radar Signals with Adaptive Digital Filters. Preprints, 21<sup>st</sup> Conference On Radar Meteorology, Edmonton, AB, Canada, American Meteorological Society, pp. 167-172.
- SIGMET, Inc. 2000: RVP7 Doppler Signal Processor User's Manual.
- Weber, M.E., Chornoboy, E.S., 1993: Coherent Processing Across Multi-PRT Waveforms. Preprints, 26<sup>th</sup> Conference on Radar Meteorology, Norman, OK, pp. 232-234.
- Weber, M.E. and Stone, M.L., 1995: Low Altitude Wind Shear Detection Using Airport Surveillance Radars. IEEE Aerosp. Electron. Syst. Mag. 10 (6), pp. 3-9.
- Zrnica, D.S., Mahapatra, P., 1985: Two Methods of Ambiguity Resolution in Pulse Doppler Weather Radars. IEEE Transactions on Aerospace and Electronic Systems, Volume AES-21, No. 4, pp. 470-483.