

Kronecker-FFT Algorithms for Multidimensional SAR PSF Processing

Prof. Domingo Rodriguez, Ph.D.

Research and Development Center of UPRM
University of Puerto Rico at Mayaguez
Road 108, Km. 1.0, B. Miradero
Mayaguez PR 00680

Tel.: (787) 833-3323

Fax: (787) 833-3339

domingo@ece.uprm.edu

Citizenship: United States

Work Areas:

Embedded Computing for Global Sensors and Information Dominance

Algorithm Mapping to High Performance Architectures

Reconfigurable Computing for Embedded Systems

Abstract

This work presents new variants of FFT algorithms (not necessarily power of two lengths), in a computational Kronecker-core array algebra setting, tailored to the efficient point spread function (PSF) processing in multidimensional synthetic aperture radar (SAR) systems. The tailoring of the algorithms is performed through a targeted study of group theoretic properties of input/output data indexing sets and associated groups of stride permutations. The advantage of these new FFT variants over conventional formulations is that additive group theoretic properties of multidimensional input/output indexing sets are used for their mathematical formulations, establishing mapping identifications between computing structures and mathematical expressions identified as factored compositions of functional primitives, reducing in this manner their computational complexity and improving their implementation performance.

There exist many formulations of fast algorithms for computing the multidimensional discrete Fourier transform (DFT). In this work, computational Kronecker-core array (CKA) algebra, a branch of finite dimensional multi-linear algebra, is used as a language to identify similarities and differences among various FFT algorithm variants as well as for the creation of new variants. Each multidimensional DFT computation is expressed in matrix form. The multidimensional DFT matrix, in turn, is decomposed into a set of factors, called functional primitives, which are individually identified with an underlying software/hardware computational constructs. It is in this identification process where the language of CKA algebra becomes instrumental. For a given hardware computational structure and multidimensional DFT matrix, there are many FFT algorithm variants which can map to this target machine. The language of CKA algebra aids the application developer in the mapping effort of identifying the more computationally efficient FFT variants and thus reducing the computational effort.

This work is partially supported by NSF Grant 99-77071

The FFT computing methods presented are currently being placed in a Weyl-Heisenberg computational framework setting for the study of real-time adaptive computation of linear arrays of cross-ambiguity functions, formulated as point surface response functions for coded and/or linearly FM modulated, time-frequency collocated, synthetic aperture radar (SAR) transmitted signals and received signals for applications in signal detection, information extraction, and clutters and jammers suppression operations. The **Figure One** below depicts a basic FFT-core functional primitive developed in MATLAB's Simulink for multi-FPGA implementation of multidimensional FFTs.

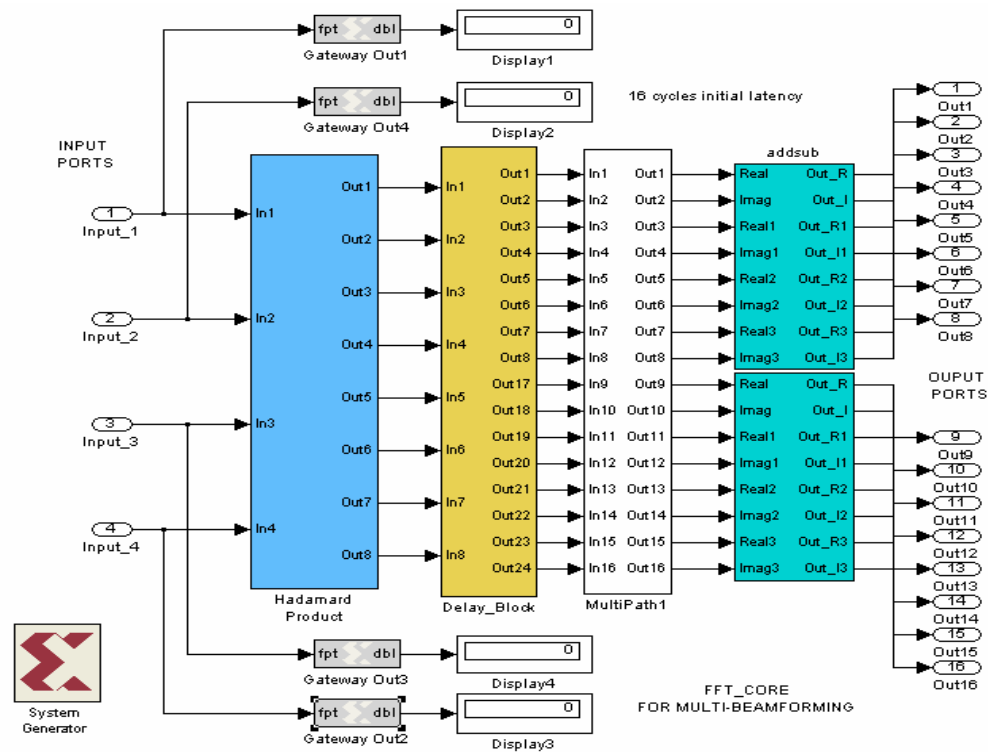

Figure One: Basic Core-FFT Simulation

References

- [1] J. Johnson, R. Johnson, D. Rodríguez, R. Tolimieri, "A Methodology for Designing, Modifying, and Implementing Fourier Transform Algorithms on Various Architectures," *Journal of Circuits, Systems and Signal Processing*, Birkhäuser, Boston, Vol. 9, No. 4, 1990.
- [2] D. Rodríguez, N. G. Santiago, H. Nava, "High Performance SAR Raw Array Data Environment (SARADAS)," *IEEE 5th European Conference on Synthetic Aperture Radar, EUSAR 2004*, May 2004, Ulm, Germany.
- [3] N. G. Santiago, D. T. Rover, D. Rodríguez, "A Statistical Approach for the Analysis of the Relation between Low-Level Performance Information, the Code, and the Environment," *Proceedings of the SIAM Journal of Parallel and Distributed Computing Practice*. Accepted for publication.
- [4] D. Rodríguez, "SAR Point Spread Signals and Earth Surface Property Characteristics," (Invited Paper), *SPIE 44th Annual Meeting and Exhibition*, Colorado, July 18-23, 1999.
- [5] D. Rodríguez, "A Computational Kronecker-core Array Algebra SAR Raw Data Generation Modeling System," *Proceedings of the Asilomar Conference on Signals, Systems, and Computers*, Monterey, California, Nov. 2001.
- [6] R. Tolimieri, M. An, "Time-Frequency Representations," Birkhäuser, Boston, 1998.

This work is partially supported by NSF Grant 99-77071