

HPEC Related VITA Standards: An Update

**Randy Banton
Mercury Computer Systems, Inc.**

**High Performance Embedded Computing (HPEC) Conference
September 30, 2004**

The Ultimate Performance Machine

- **Switch Fabric Backplane**
 - VITA 41 “VXS” (VME Switch fabric Serial)
 - VITA 46 “AMF” (Advanced Module Format)
- **Switch Fabric Mezzanine**
 - VITA 42 “XMC” (Switch Fabric Mezzanine Card)
- **Rugged Mechanical Infrastructure**
 - VITA 48 “ERDI” (Enhanced Ruggedized Design Implementation)
- **Serial I/O**
 - VITA 17.2 “10Gb SFPDP”
- **Digital Intermediate Frequency Interface**
 - VITA 49 “Digital IF”

VITA 41

"VXS"

(VME Switch Fabric Serial)

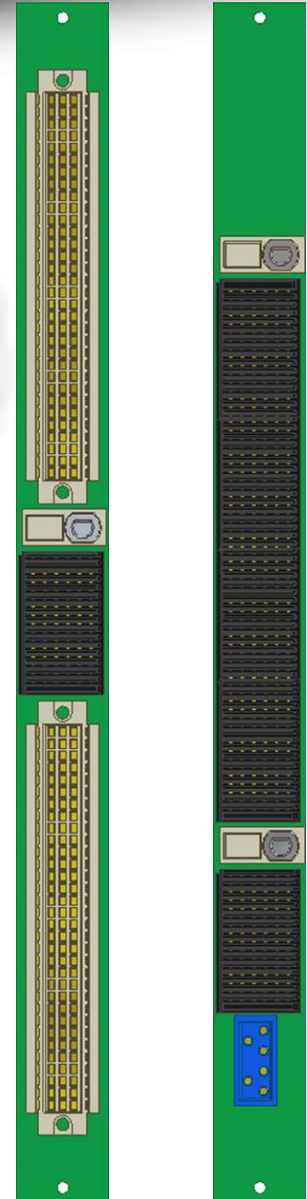

The Ultimate Performance Machine

VITA 41 & VITA 46

Adding multi-gigabit serial interconnects to VME type infrastructures

- **All approaches need new backplanes**
 - Existing connectors are not multi-gigabit capable

- **All approaches can have some backward-compatible VME slots**
 - **VITA 41:**
Upgrade P0; Keep P1 & P2 DIN connectors
 - Also define switch card with all new connectors

 - **VITA 46:**
Upgrade all connectors
 - Also include current VME slots in backplanes

VITA 41 “VXS”

- Replace existing P0 with Multi-Gig RT2 7-Row

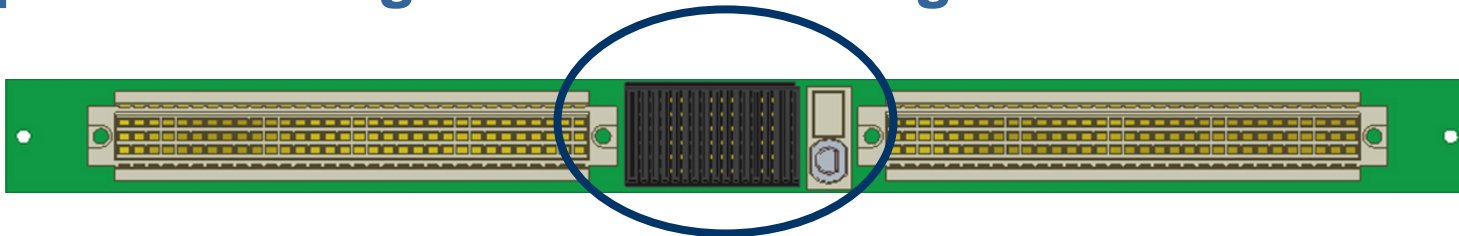

- Add switch slots using all Multi-Gig RT2 9-Row



- Upside

- **Backward compatibility with P1, P2 DIN connectors**

- Downside

- **Not compatible with boards using existing P0 2mm connector**
- **Limited number of high-speed pins in new P0 Multi-Gig connector**
- **Connectors not 2-level maintenance ready**
- **3U format does not benefit from new P0 connector thus no allowance for high-speed signaling upgrades**

VITA 41 Backplane

Example Configuration

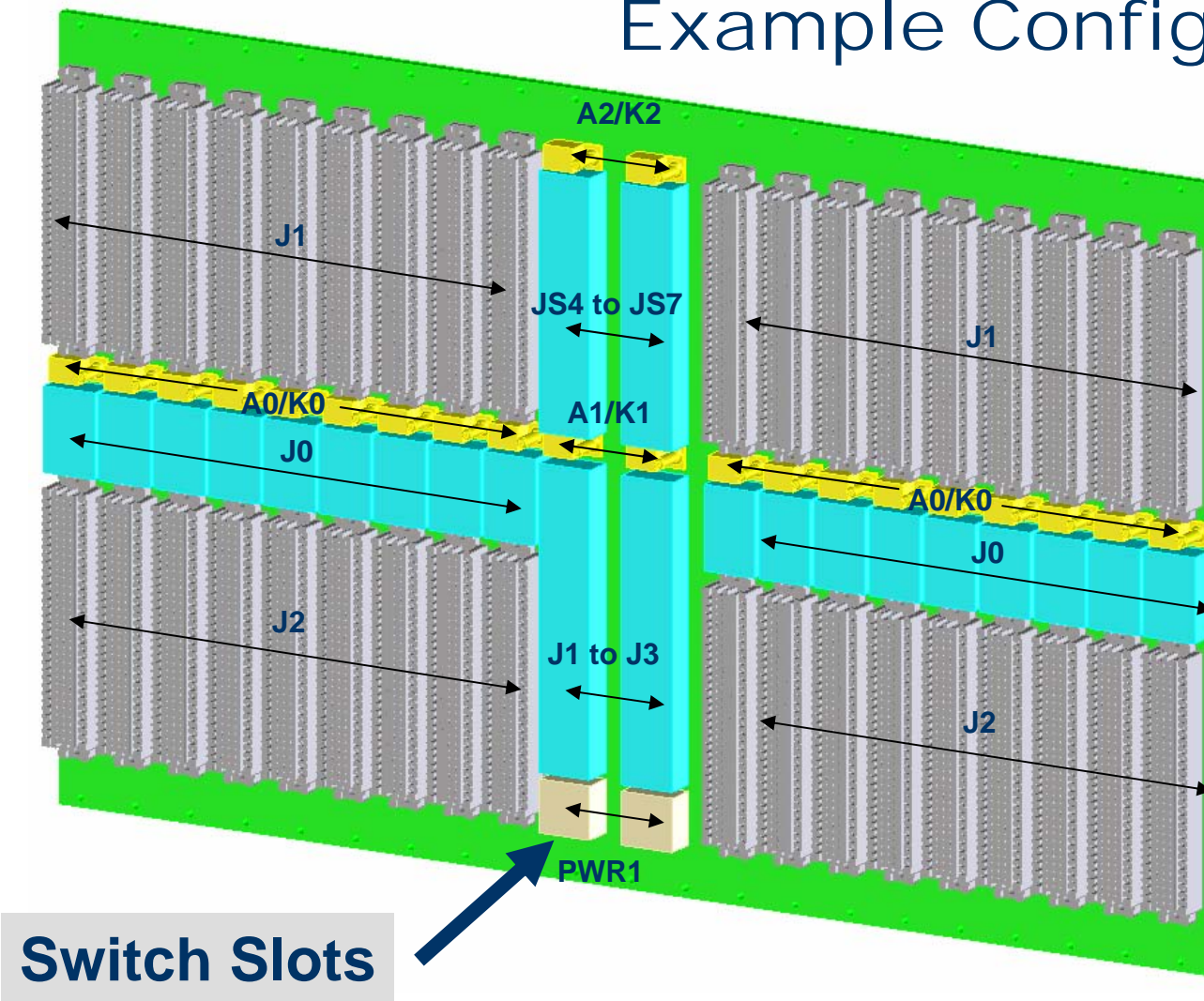

Switch Slots

○ Status

– VITA 41.0 base standard

- Completed, drawings being updated

– Protocol mappings

- VITA 41.1 Infiniband; completed
- VITA 41.2 Serial RapidIO[®]; completed
- VITA 41.3 Ethernet; in process
- VITA 41.4 PCI Express; in process
- VITA 41.11 RTM (Rear Transition Module); in process

VITA 46

"AMF"

(Advanced Module Format)

The Ultimate Performance Machine



VITA 46 “AMF”

- Replace all connectors with Multi-Gig RT2 7-Row

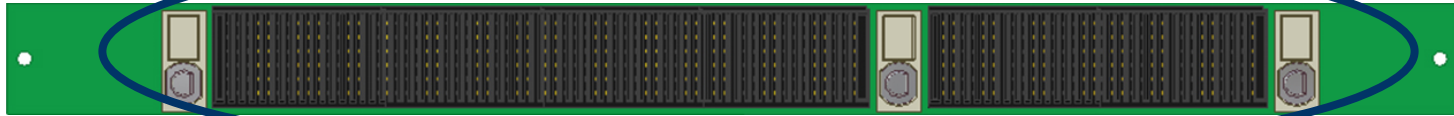

- **No switch card required**
 - Enough pins are available to build large, rich topologies without one
- **Upside**
 - Enough high-speed pins (192 pairs) for switch fabric *and* large I/O counts
 - Backward VME compatibility in some slots with VME on new connector
 - Includes a 3U version, with high-speed serial I/O and fabric
 - 2-level maintenance ESD ready connector system
- **Downside**
 - Not compatible with existing boards at slot level; No DINs for P1 & P2
 - Backward VME compatibility in some slots with VME on new connector

Example VITA 46 Hetero- Backplane

Heterogeneous Backplane for VME Legacy

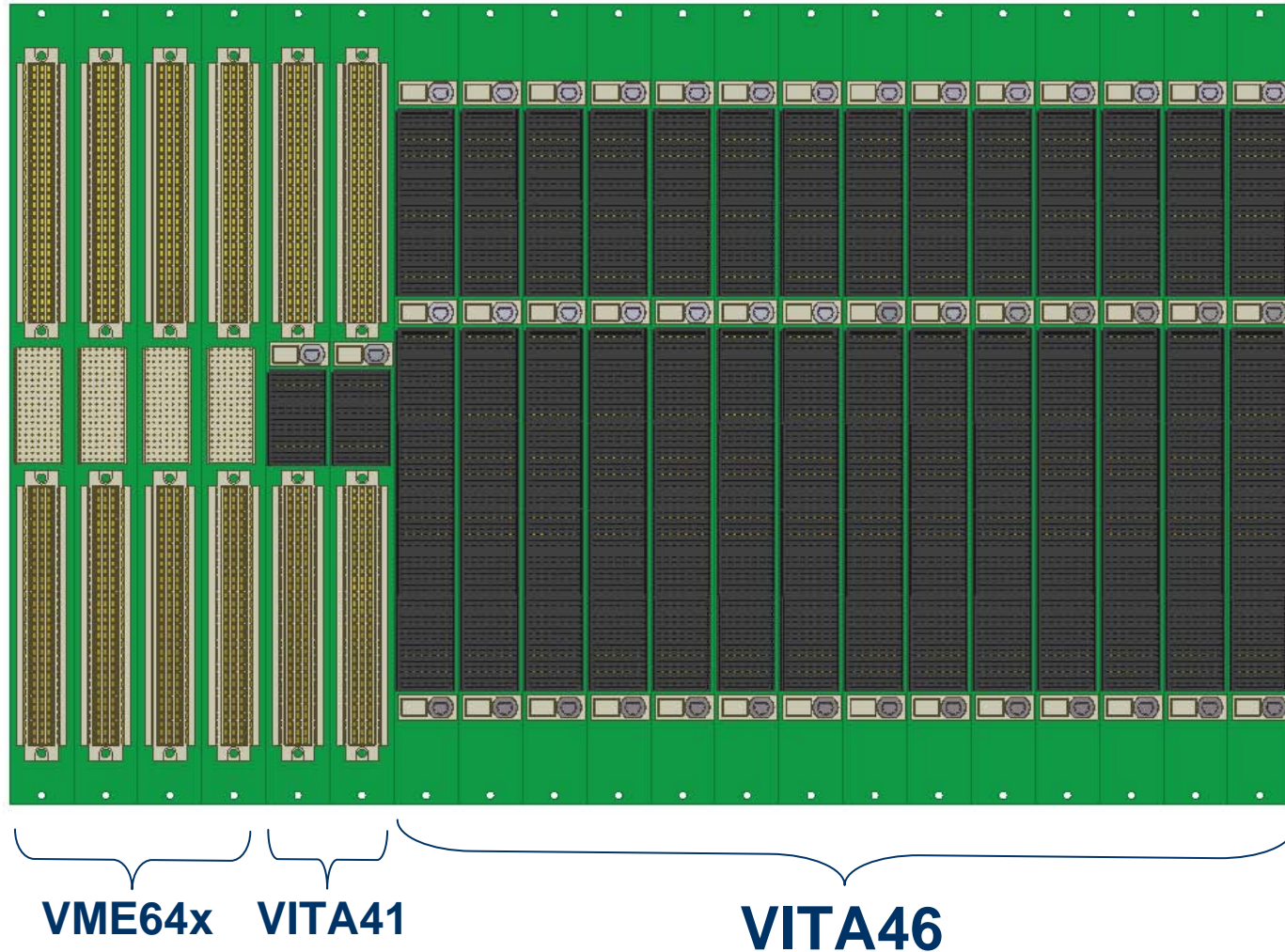

○ Status

– VITA 46.0 base standard

- In process, draft in review

– Protocol mappings

- VITA 46.1 Parallel VME; in process
- VITA 46.2 Parallel cPCI; planned
- VITA 46.3 Serial RapidIO; planned
- VITA 46.4 PCI Express; planned
- VITA 46.5 HyperTransport™; planned
- VITA 46.x RTM (Rear Transition Module); planned

VITA 42

"XMC"

(Switch Fabric Mezzanine Card)

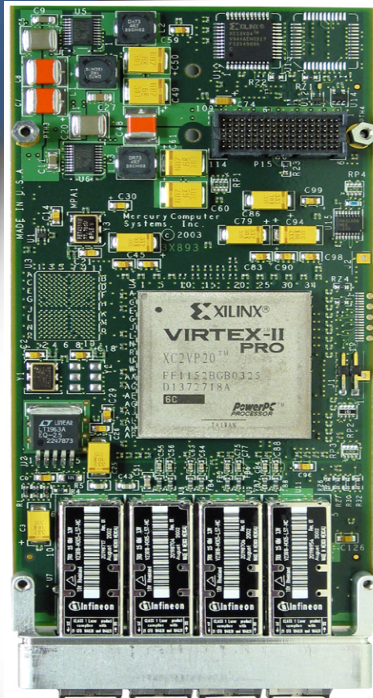

VITA 42 “XMC”

- **Began as RapidIO Trade Association “RMC”**
 - Transitioned to VITA for standardization
- **Adds high-speed connector to existing CMC format**
- **Options for different protocols**
 - VITA 42.1 Parallel RapidIO
 - VITA 42.2 Serial RapidIO
 - VITA 42.3 PCI Express
 - VITA 42.10 general purpose I/O



**4 GB memory XMC
with Parallel RapidIO**

Example XMCs

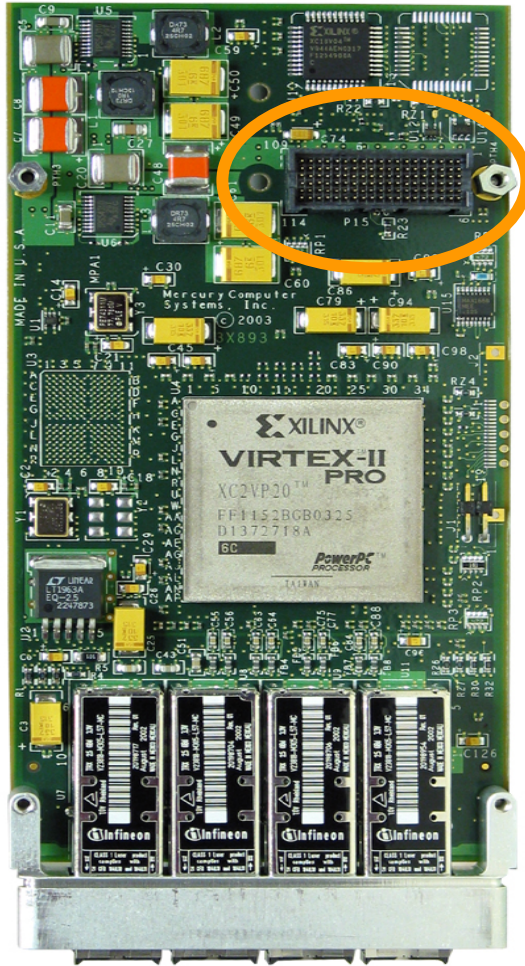

Interchassis XMC with Parallel RapidIO and 4 fiber I/O connectors running Serial RapidIO

Note – only 1 connector required for basic XMC. PMC connectors are optional.

○ Status

– VITA 42.0 base standard

- In process, final draft in review

– Protocol mappings

- VITA 42.1 Parallel RapidIO; in process
- VITA 42.2 Serial RapidIO; in process
- VITA 42.3 PCI Express; in process
- VITA 42.10 general purpose I/O; in process

VITA 48

"ERDI"

(Enhanced Ruggedized Design Implementation)

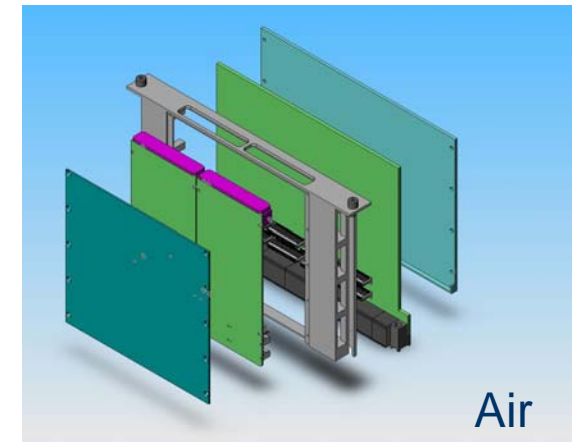
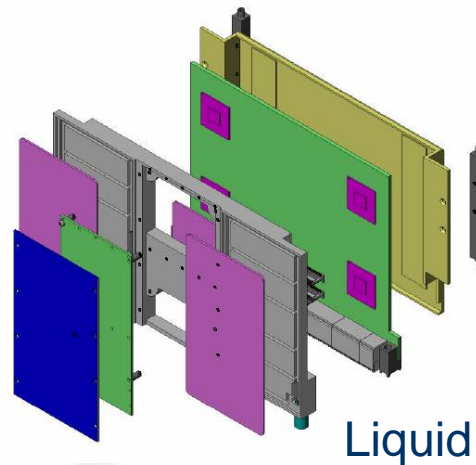
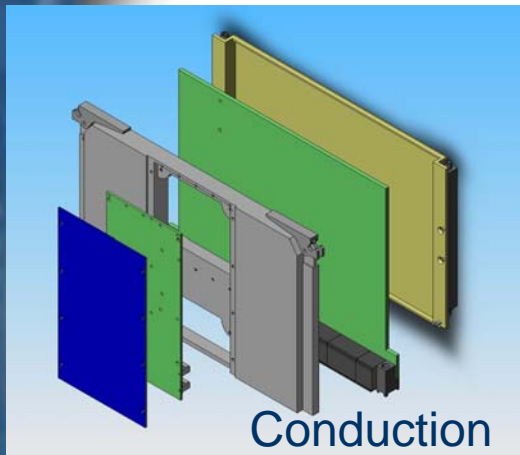

The Ultimate Performance Machine

VITA 48 “ERDI”

As compared to present day IEEE1101.x standards ...

- **Board space & volume**

- Space-saving methodologies possible
- New allocations of PWB thickness for high-density routing and power distribution, increased secondary-side components heights

- **Ruggedization**

- Improved methodologies for “out of the box” MIL-deployable ruggedization

- **Thermal management**

- Unification of air-, conduction-, liquid-flow-thru-, and spray cooling methods
- Improve ability to thermally managed secondary side of PWB
- Allow for significant thermals planes in the PWB in addition to increased routing layers

- **Two-Level maintenance**

- ESD protection at the board level in combination with other improvements
- Applies to all cooling methodologies

... and complementary to IEEE1101.x standards. There is no intent to “replace” these standards that still are useful in many other applications.

Commercial Market Driven Standards Not Sufficient

- **Standards such as PICMG ATCA are pushing 40-50 CFM per slot for 150-200W power and 55C-like environments**
 - **10-20 CFM for military deployments tends to be the platform limit for air-cooling**
- **No commercial standards are pushing forward on non-air-cooled methodologies**
 - **85C card cage desired for conduction-cooled solutions, 70C card edge often the lower acceptable limit**
 - **MIL-*deployable* liquid cooling (e.g., liquid flow-thru) appears to becoming a technology and MIL-platform reality in next 3-5 years**
- **In general, new generation of commercial standards is not targeting the harsh shock, random vibration, endurance vibration, temperature, altitude, humidity, etc. of the HPEC MIL-deployed world**

VITA 48 Air-Cooled Module

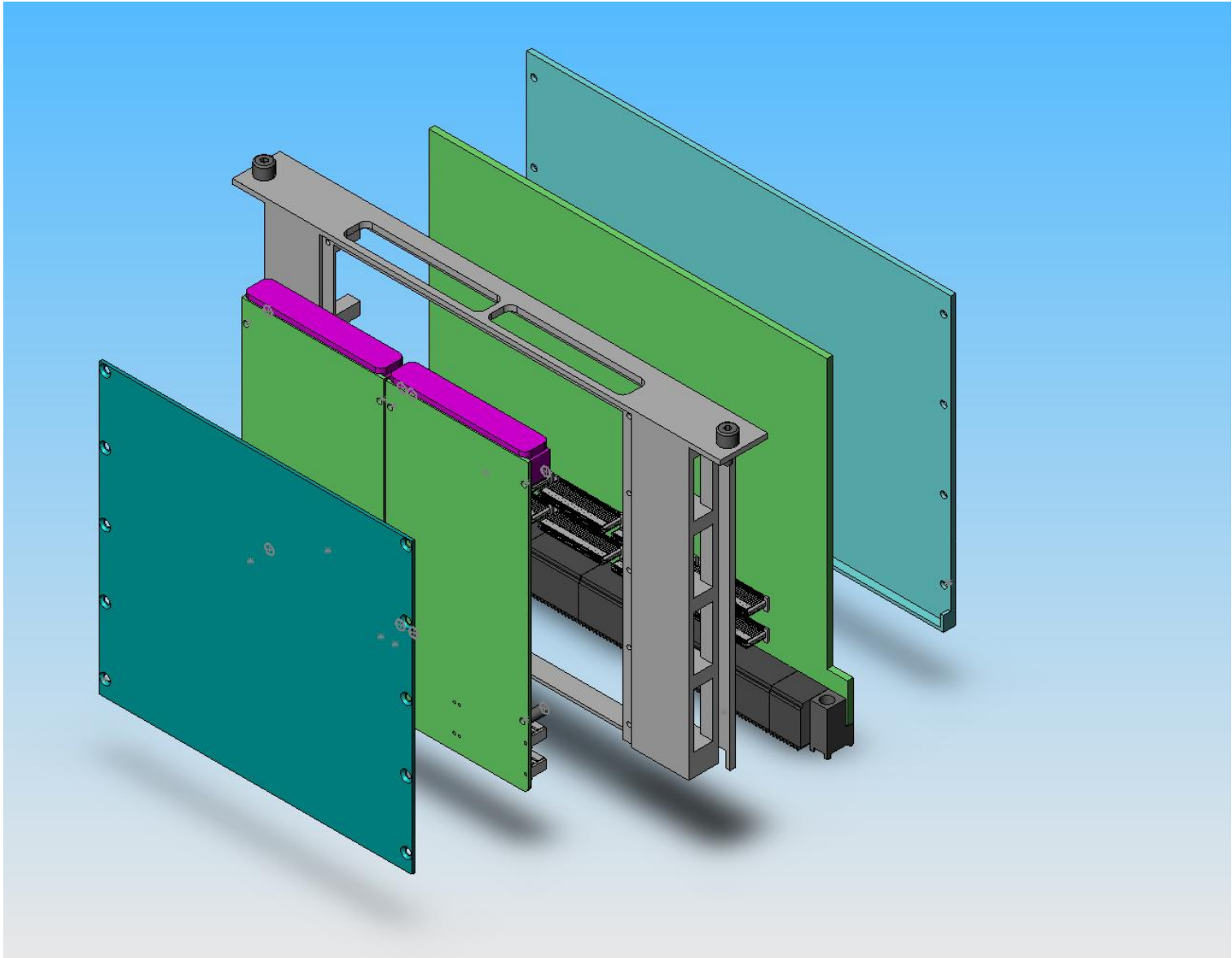

VITA 48 Conduction-Cooled Module

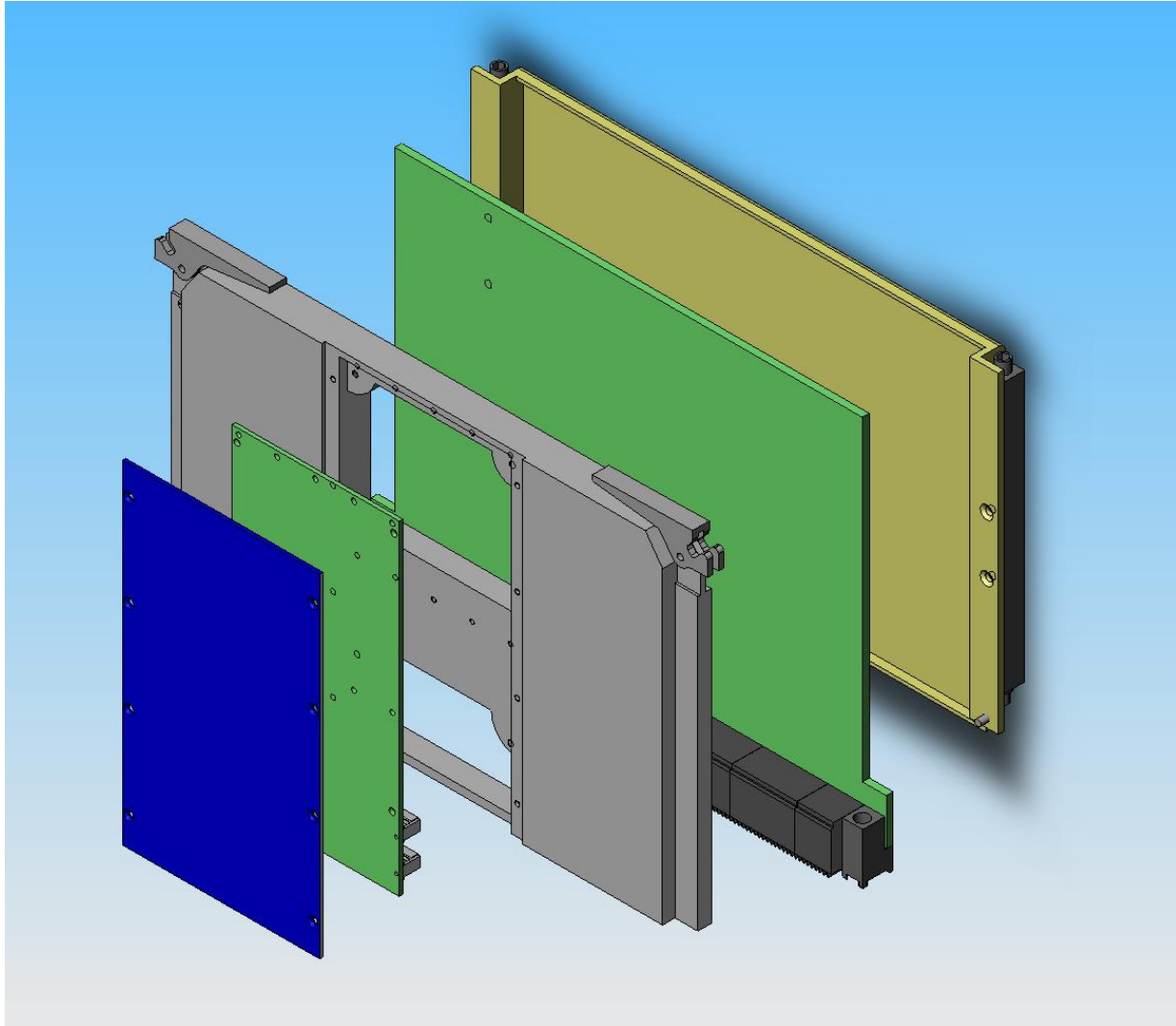

VITA 48 LFT Module

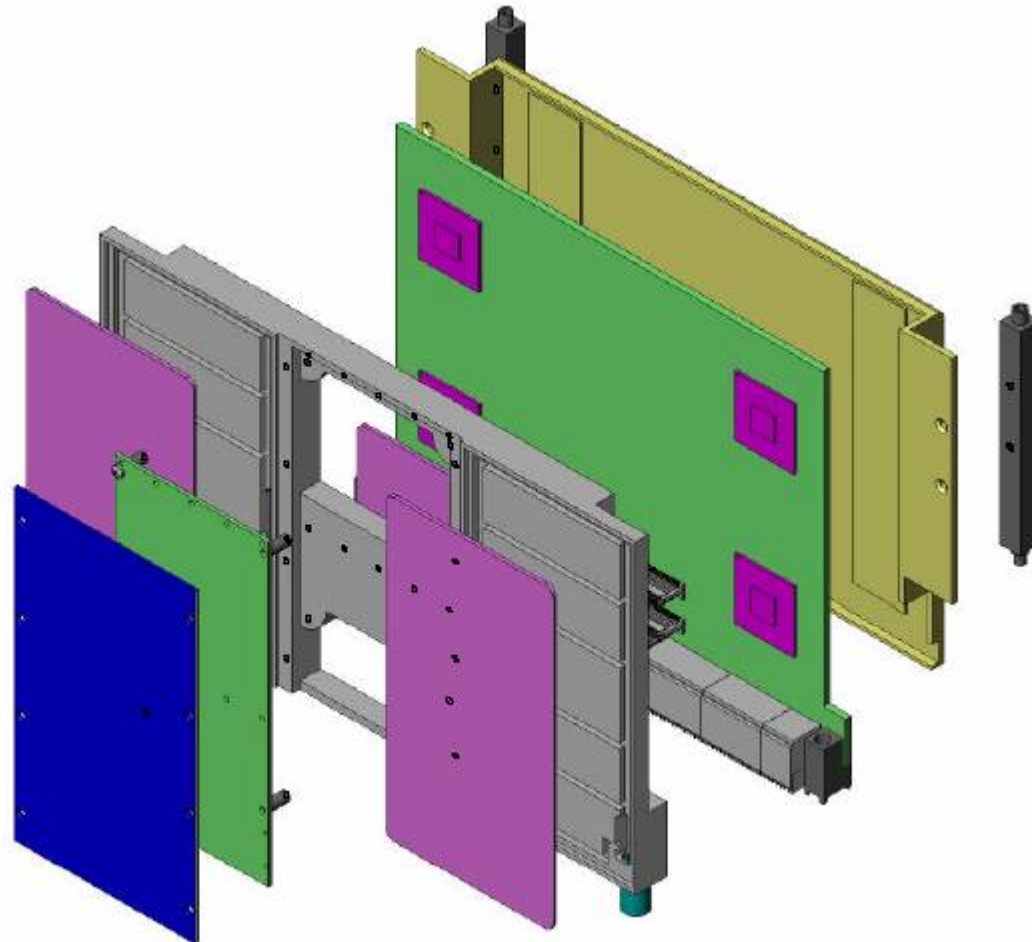

○ Status

– VITA 48.0 base standard

- In process, draft in review

– Connector system mappings

- VITA 48.1 - VITA 46 connector system; in process
- VITA 48.2 - VME64 connector system; planned
- VITA 48.3 – cPCI connector system; ?

Thank You!