



NALLATECH

The High Performance
FPGA Solutions Company



NALLATECH

High Performance Embedded Computing using FPGAs

Nallatech Inc
September 2004

Nallatech

- The Professional Leader in Innovative, Low Risk and High Performance FPGA Processing Solutions for Customers' Challenging Applications
- Comprehensive product range delivers
 - Highest performance-density
 - Maximum scalability
 - Most complete solutions available on the market today
- Official Xilinx Diamond Xpert Partners



NALLATECH

The High Performance FPGA Solutions Company

Microprocessors to FPGAs

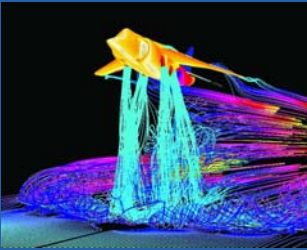

Nallatech have over 10 years
FPGA system experience

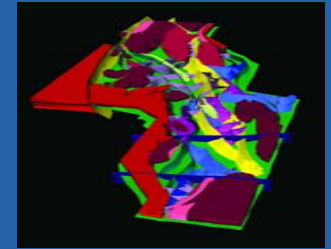

- ✓ High performance
- ✓ Flexibility



- ✓ Low latency
- ✓ Low cost

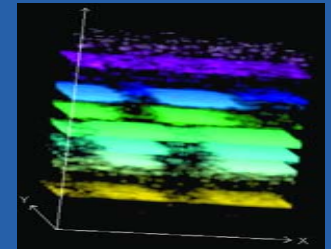

- ✓ Low power consumption
- ✓ Scalability



- ✓ Obsolescence mitigation
- ✓ Easily upgradeable

- ✓ SWAP



NALLATECH

The High Performance FPGA Solutions Company

Nallatech COTS Products

- Key Product features
 - Unique high-speed hardware architecture
 - Support for industry standard VME, cPCI, PCI and PC/104*plus*
 - Support for the most popular operating systems, programming languages and tools.

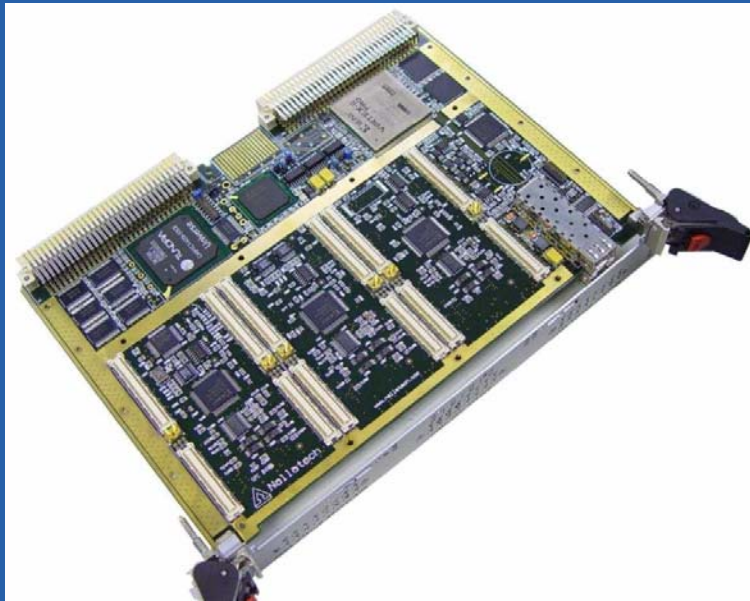

VME



PC104*plus*





NALLATECH

The High Performance FPGA Solutions Company

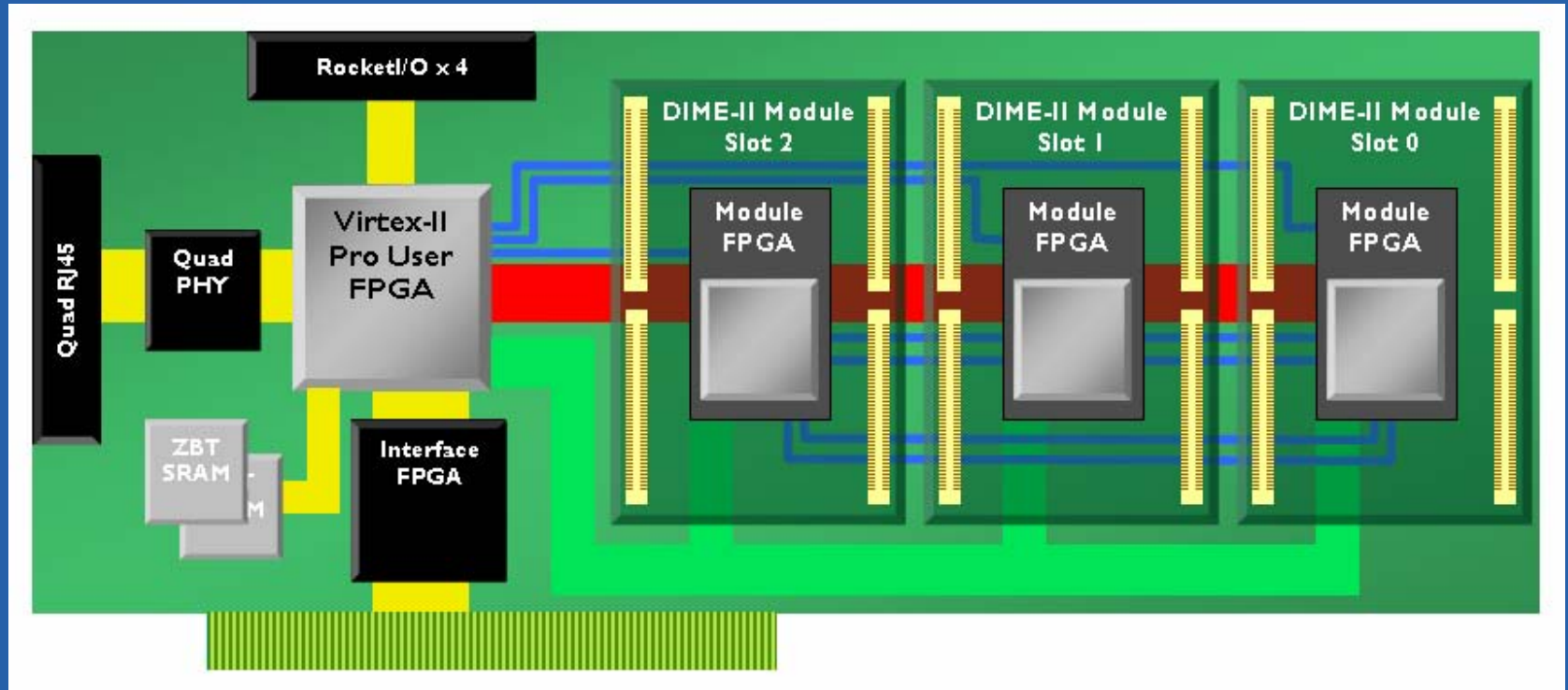
DIME-II Motherboard Architecture

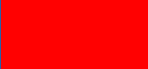

-  Local Bus and GPIO – 64+21 bits / 66MHz
-  P-Links – 12 bits / 100MHz
-  Adjacent Bus – 122 bits / 100-166MHz

N Body HPEC - Starfield Simulation

N Body Problem: “*Starfield Simulation*”

Gravity model calculating position and velocity of each particle.

Computationally intense since number of interactions is proportional to the square of the number of bodies.

Implemented on a Nallatech PCI card featuring 4 Xilinx 2V6000 FPGAs.

Simulation was implemented using Nallatech’s own optimized IEEE-754 floating point cores and “DIMETalk” – Nallatech’s FPGA communication tool.



By pipelining the multiple force calculations, the simulation was massively accelerated – performing more than 400 floating point calculations in parallel, resulting in a sustained performance of 18 GFlops. When the same calculations were executed on the Host 2.4GHz Pentium 4 processor, the performance level dropped to 0.2 GFlops.

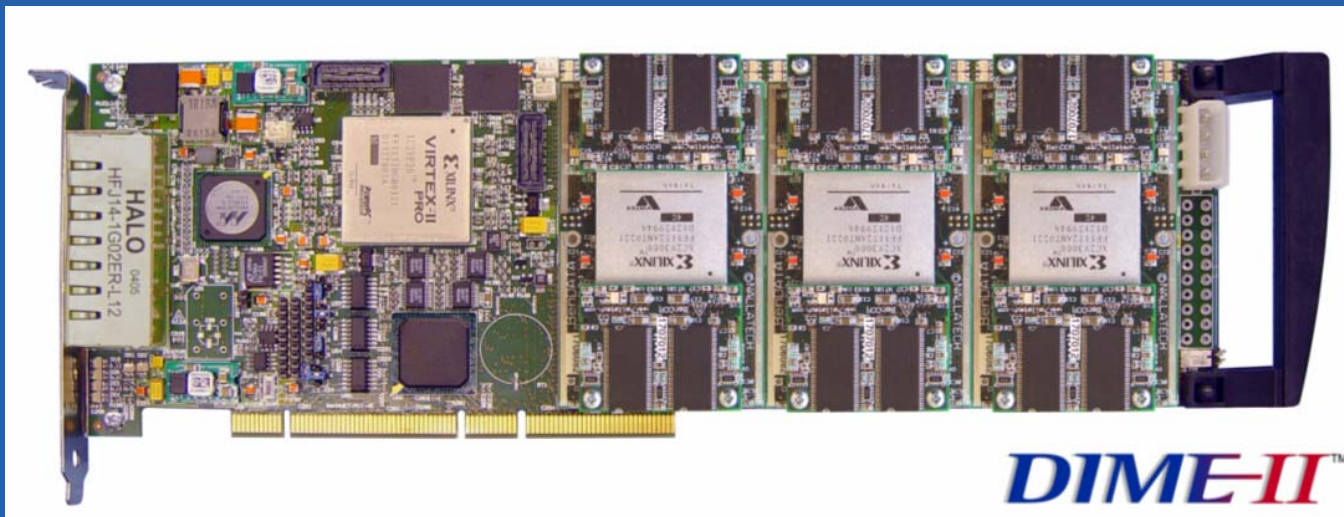
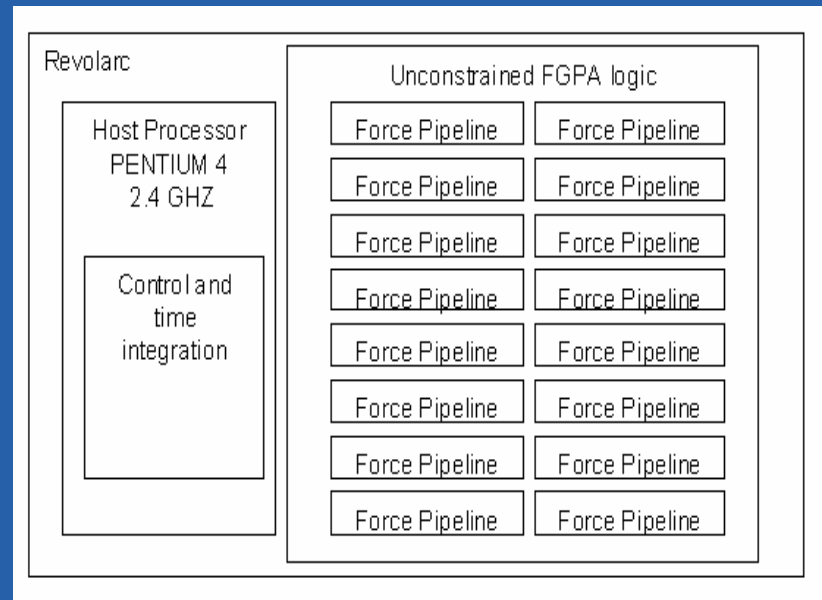

The figures below illustrates the floor plan of one of the XC2V6000 FPGAs used in this example design, and the number of floating point arithmetic units achieved. The rectangular blocks represent the different floating-point arithmetic units implemented on the FPGA. The floating point cores used in this application were written using VHDL and were floor planned onto the target FPGA in order to make efficient use of the FPGA resources and to achieve operating frequencies approaching 150MHz.

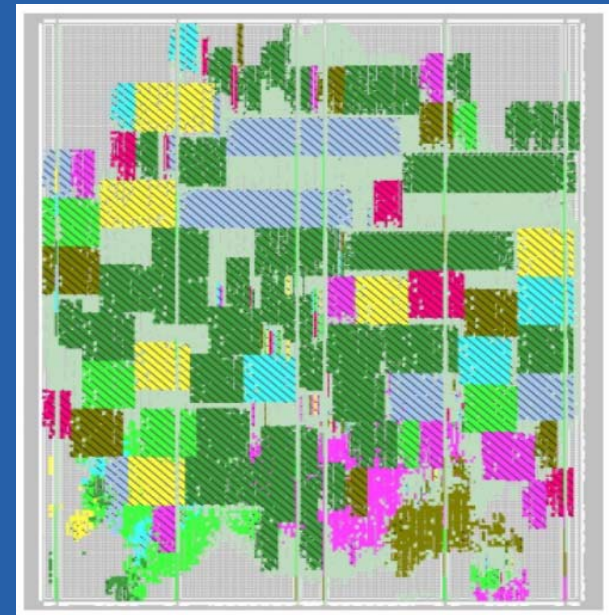
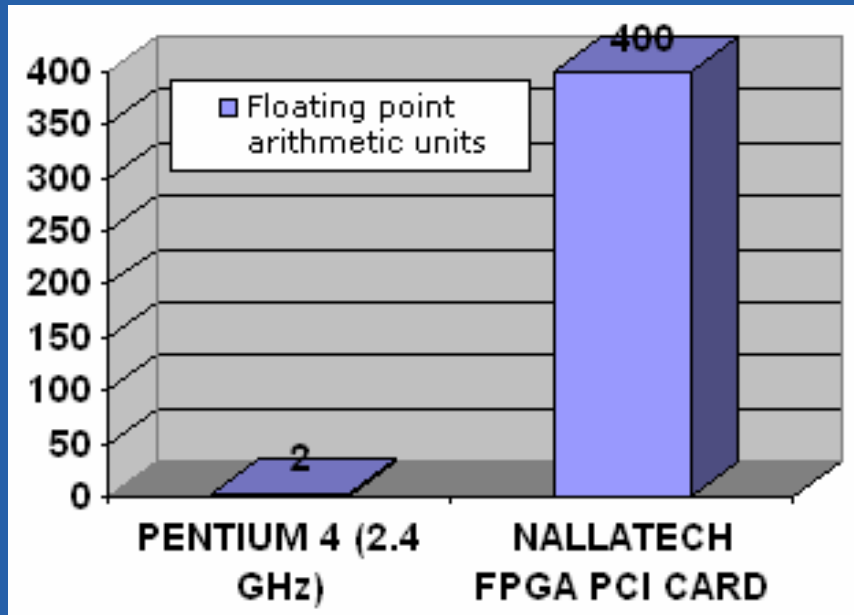

FPGA Performance Figures

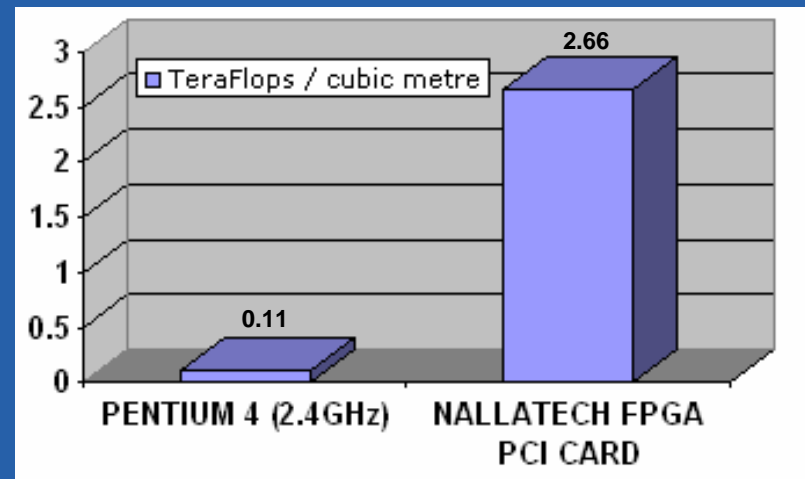
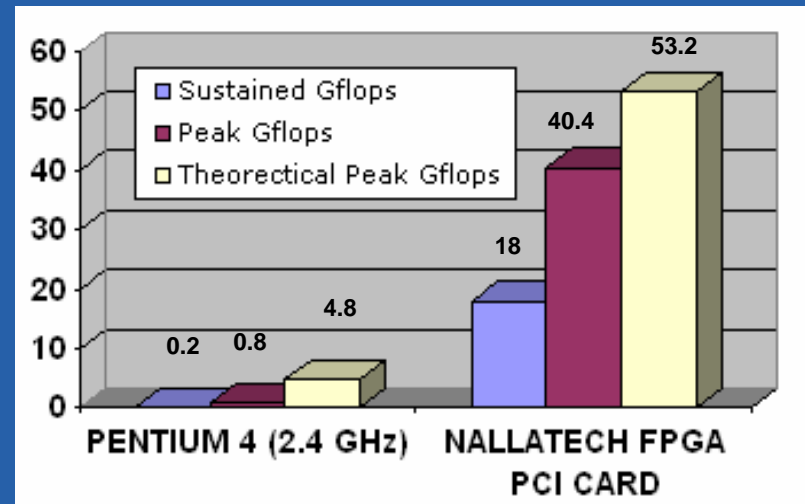
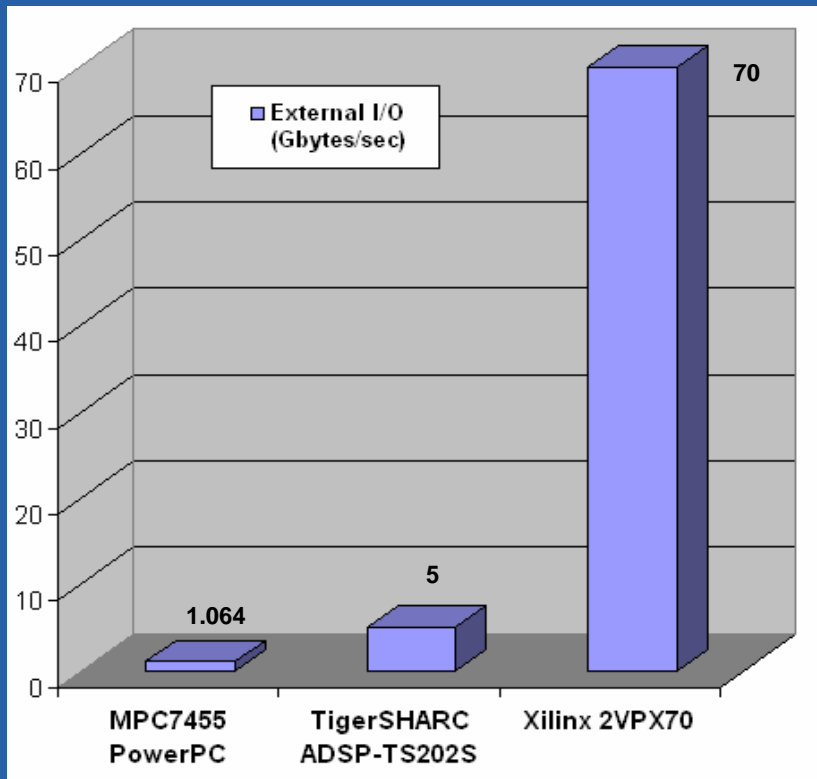

FPGAs offer highest performance density and I/O bandwidth



Hardware-in-the-Loop HPEC

Image Generation for Real-Time Particle Models (HWIL)

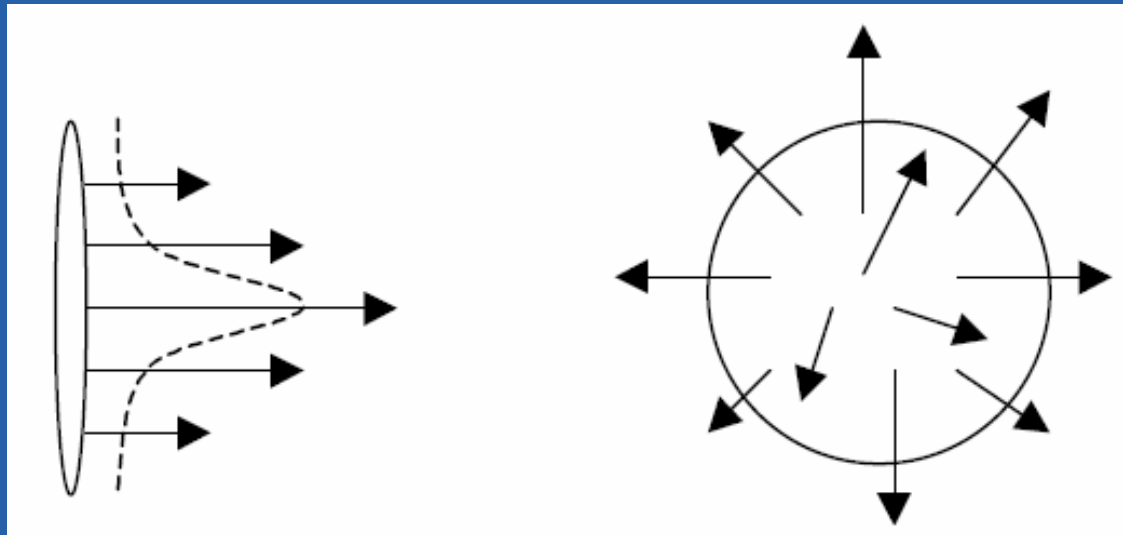

Nallatech COTS hardware featuring Xilinx FPGAs were used to model thousands of individual particles at frame rates over 100Hz and a resolution of 1024x1024 in order to create highly realistic signatures in terms of spatial dynamics and IR signature. Particle models are ideal for simulating dynamic objects such as flares, exhaust plumes, fires and explosions.



This real time HWIL application demonstrated that FPGA designs are capable of performing simple graphical models such as particle methods with impressive results.

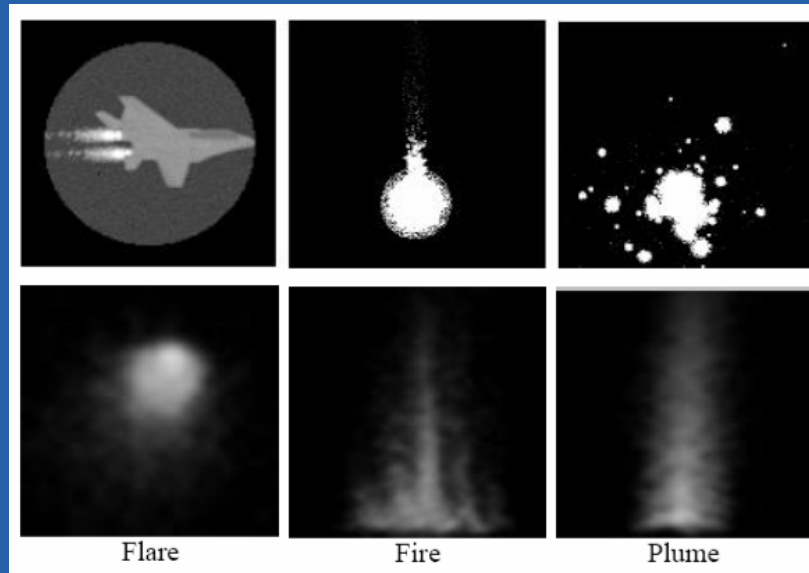

The implementation used the Nallatech DIME architecture which facilitated an infra-structure amenable to FPGAs, offering plug and play support, flexibility and scalability. This ensured that the application work carried out could be easily transposed to other variants of systems which may offer more capacity or interface to different video channels.



Real Time Image Processing HPEC

The Nallatech PC104*plus* solution was used for a SWAP constrained HPEC system used to perform real time image process with a mass storage interface. The application was deployed on a commercial aircraft operating at high altitude, with a high-resolution camera being used to capture the effects of atmospheric turbulence.

- High resolution camera obtained raw image data
- FPGAs performed real time image processing
- Data formatting and control passed data to 1TByte of storage space
- System was developed using a PC104*plus* form factor
- Onboard system was size and power constrained

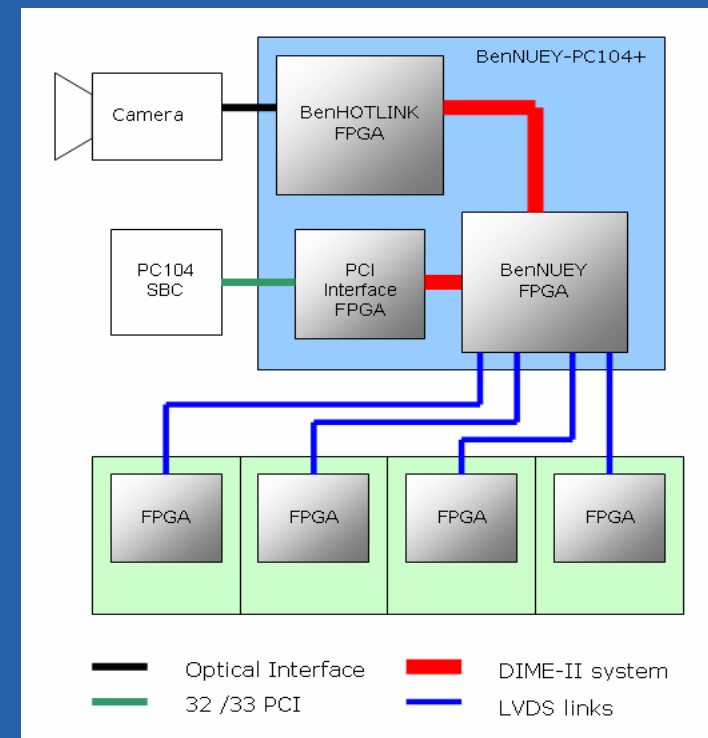



The flexibility of the FPGAs allowed sections of the design to be optimized without physically altering the hardware, while the availability of the spare DIME-II module slots on the BenNUEY-PC104+ offered the customer the option of scaling the system to support additional SCSI disks.





NALLATECH

The High Performance
FPGA Solutions Company