

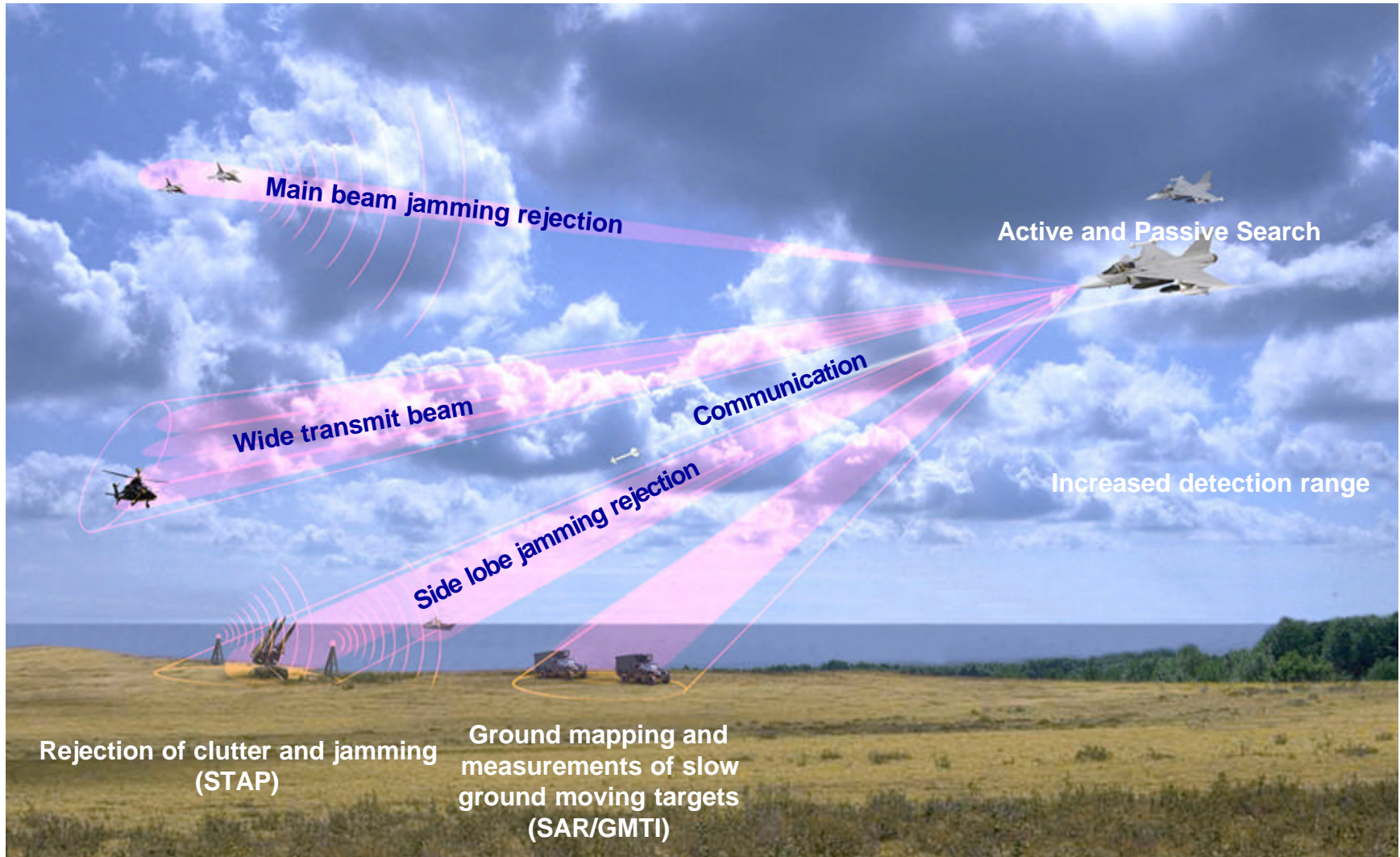

# Improved air combat awareness

- with AESA and next-generation signal processing





## The challenge

---

- The AESA performance should fit in the same “box” as today’s systems, considering
  - Physical size
  - Power dissipation
  - Physical robustness
- The High Speed Signal Processing (HSSP) project
  - A joint project between Ericsson Microwave Systems and Halmstad University, Sweden
- The goal of HSSP: “1 TFLOPS in a shoe box”

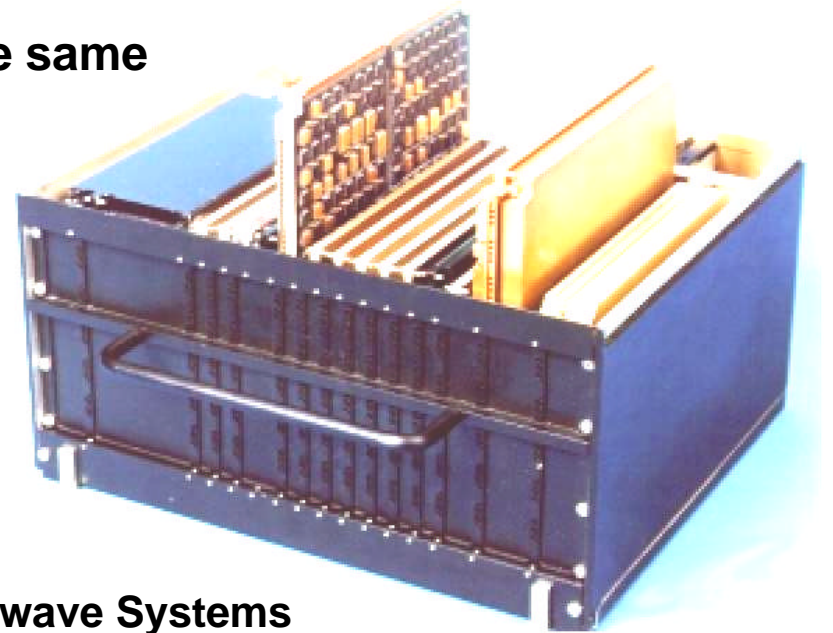



# High Speed Signal Processing project

---

- **Research for the FUTURE**

- Embedded high speed signal processing computer systems for the next generation fighter aircraft radar.

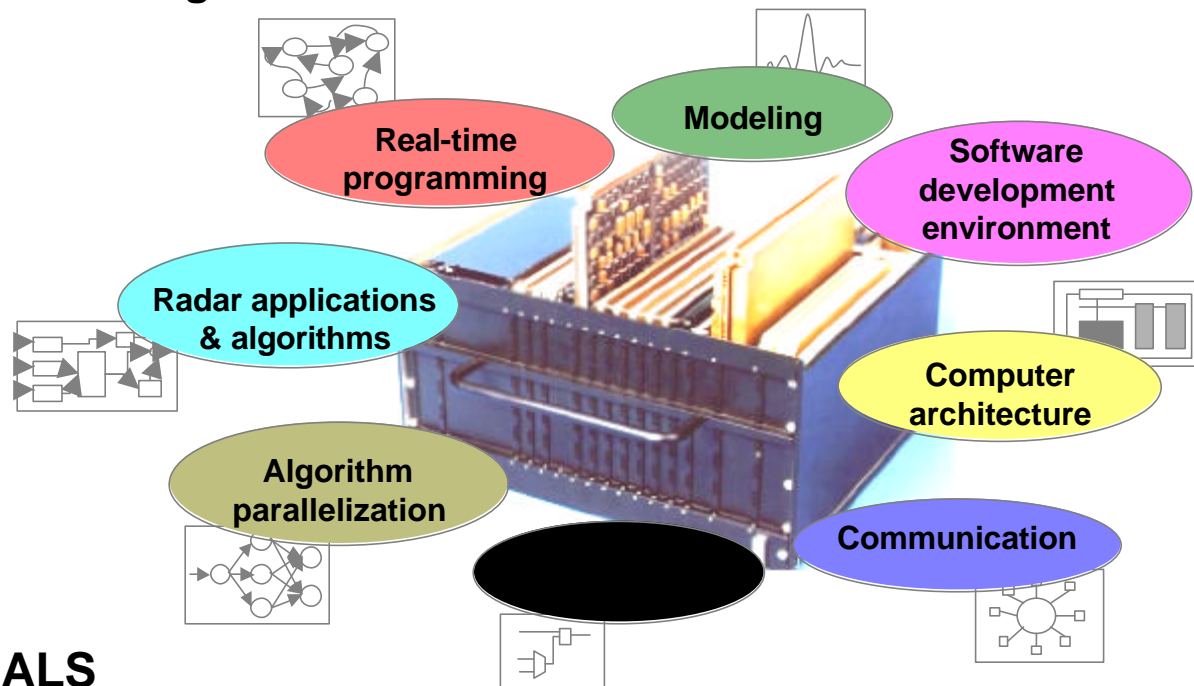

- **Our GOALS**

- Strengthen our competence to ensure realization in the future
- Find engineer efficient and economic solutions
- Actively cooperate in a wide competence network



## System realization

---

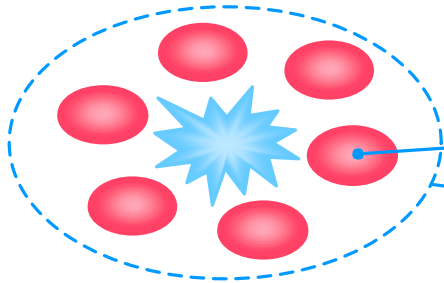

- **A multi-module system concept**
  - SIMD compute engines for high performance
  - MIMD on system level for flexibility
  - Identical compute engines

- Realizable with 0.13  $\mu\text{m}$  technology (LSI Logic G13)
- The system is based on in-house SIMD based ASICs (the compute engines)
- The modules are interconnected in a ring topology by a high speed communication network (GLVDS)
- The system scales to >1 TFLOPS

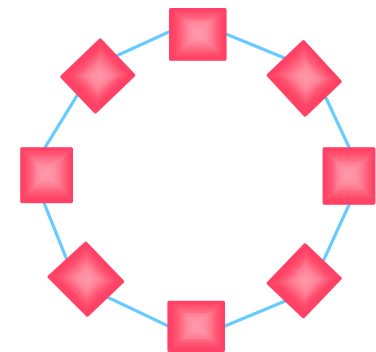



# HSSP system

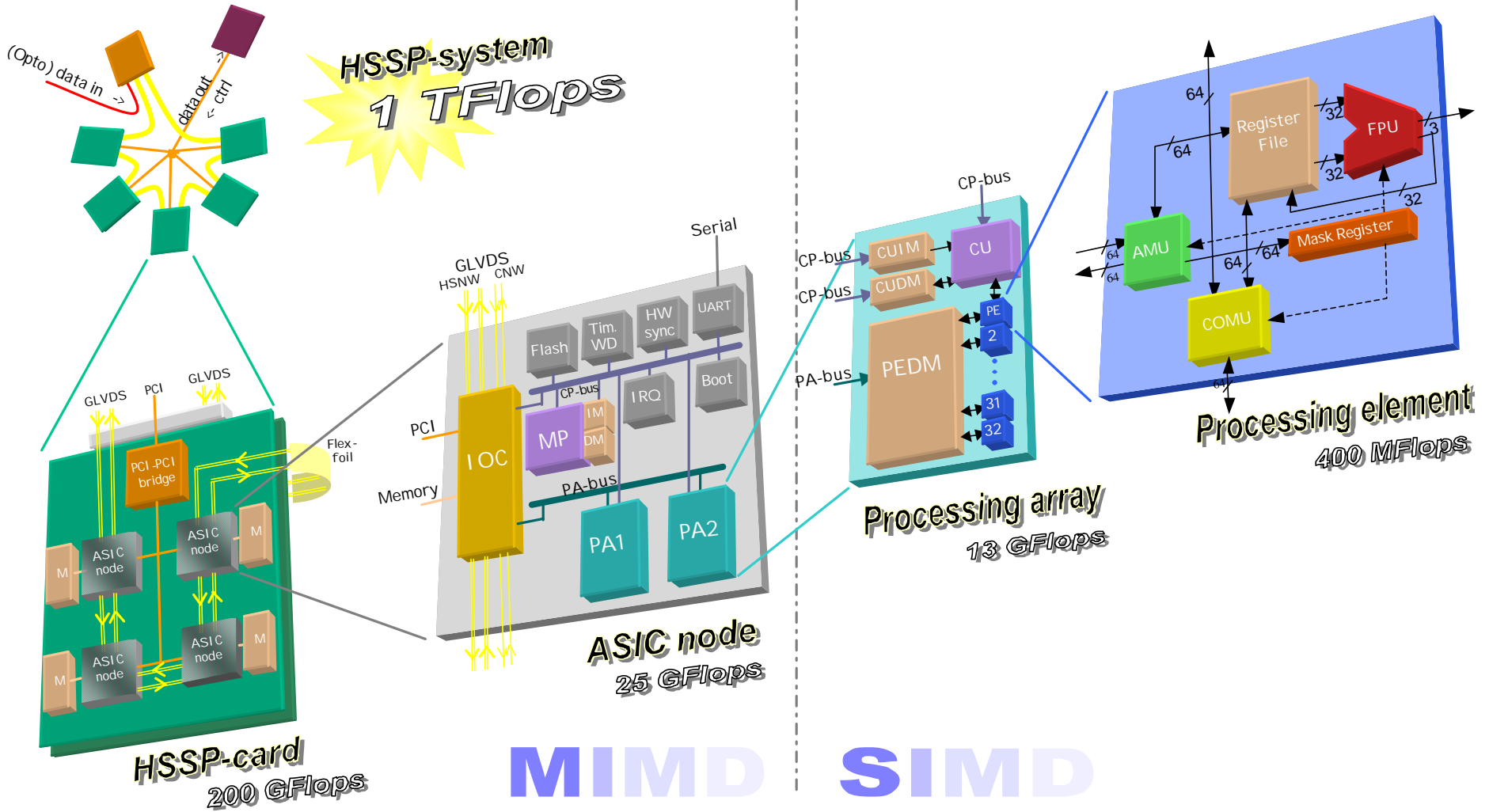



# HSSP system

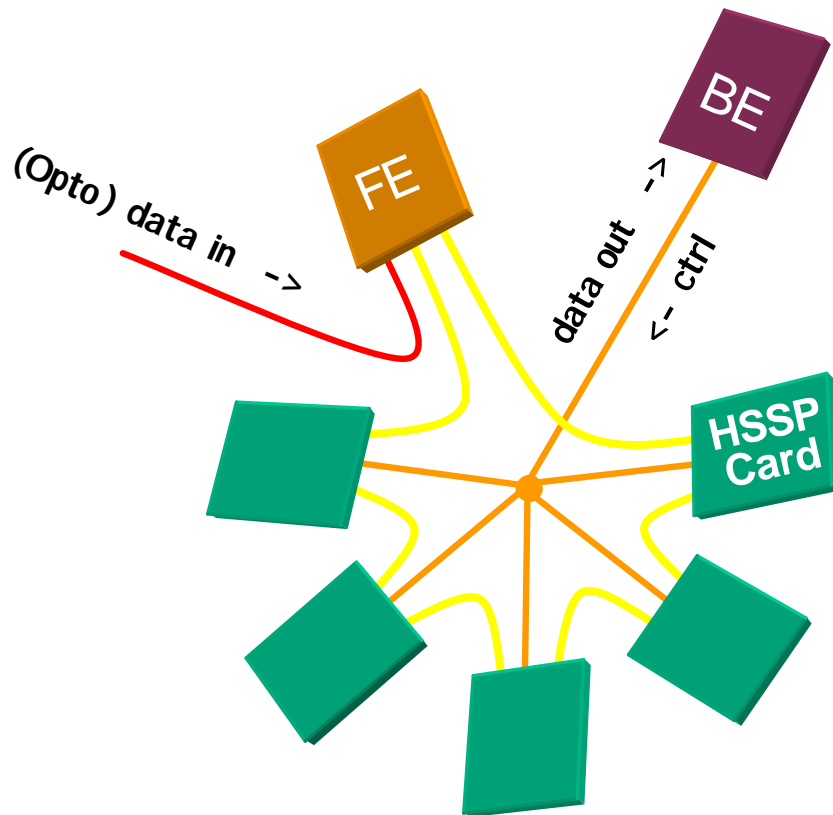

- Five HSSP cards (cassettes)
- High speed ring network
- Utility bus
- Front end (FE) with opto-interface
- Back-end (BE) with utility bus interface
- Performance: >1 TFLOPS

MIMD



## HSSP card (cassette)

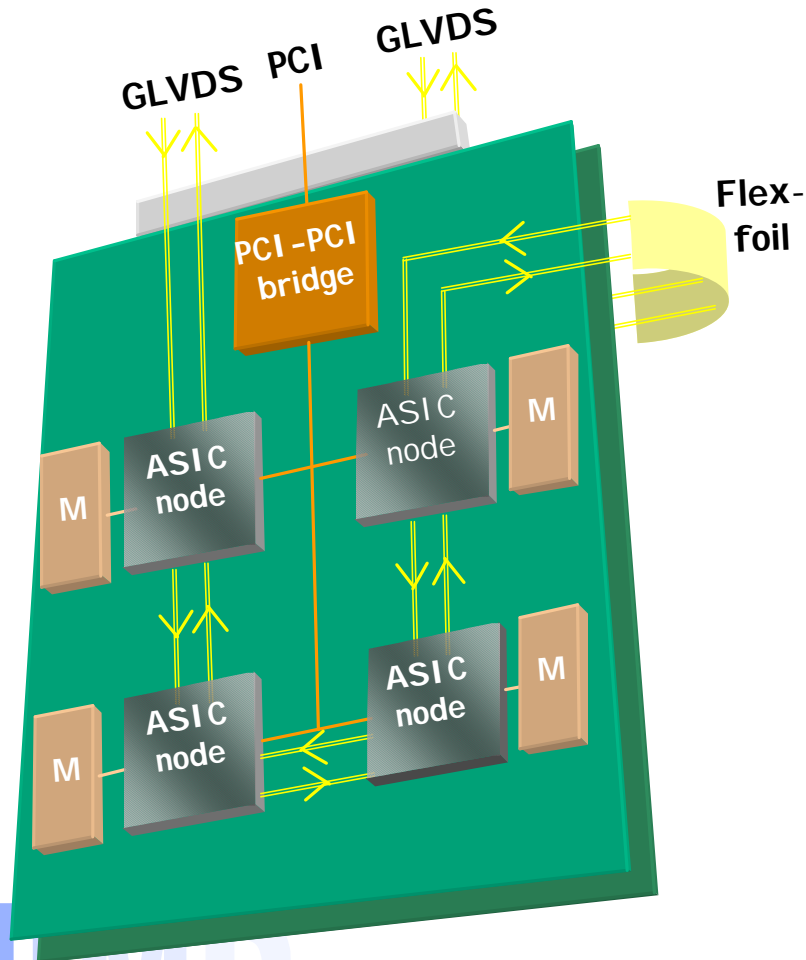

- 8 ASIC nodes per board, 4 on each side
- Double direction GLVDS ring network with separate data (1.6 GB/s) and control channel (100 MB/s)
- Utility bus
- DRAM
- Performance: 200 GFLOPS

MIMD



## ASIC node

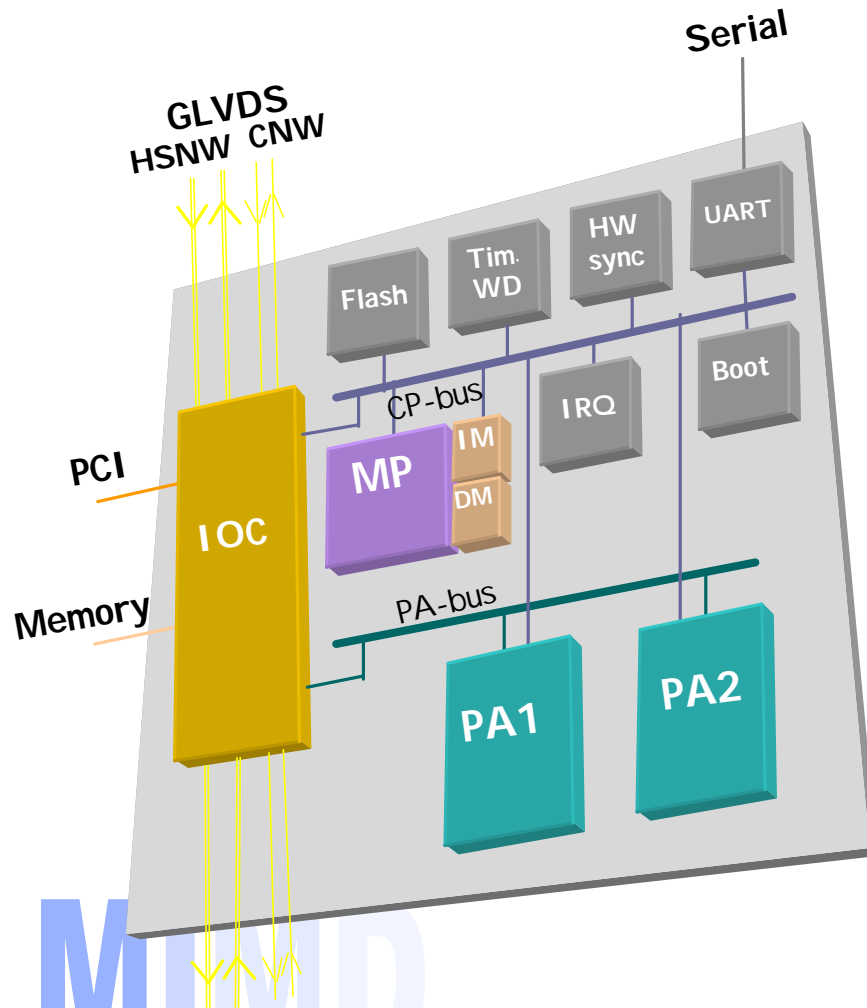

- Two processor arrays, acting as co-processors
- Master processor, IP-core running a commercial RTOS
- I/O-processor (DMA, data transformations, etc.)
- Support functions (Boot, UART, Timer, etc.)
- 0.13 $\mu$ m technology minimum
- Performance: 25 GFLOPS

MIMD



## Processor array (PA)

- 32 processor elements, 400 MHz, ring topology
- 32 kB memory per element
- Custom control unit w/ memory
- Performance: 12.5 GFLOPS

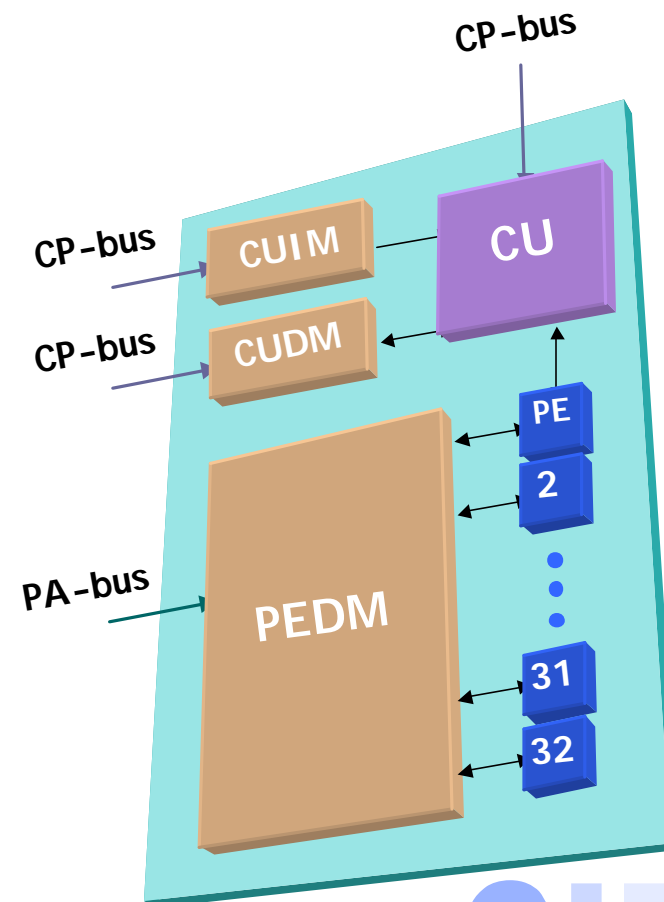





# Runtime environment

- Commercial RTOS based
- Custom libraries
- Layered architecture

-  In house development
-  Commercial RTOS/IDE
-  Hardware

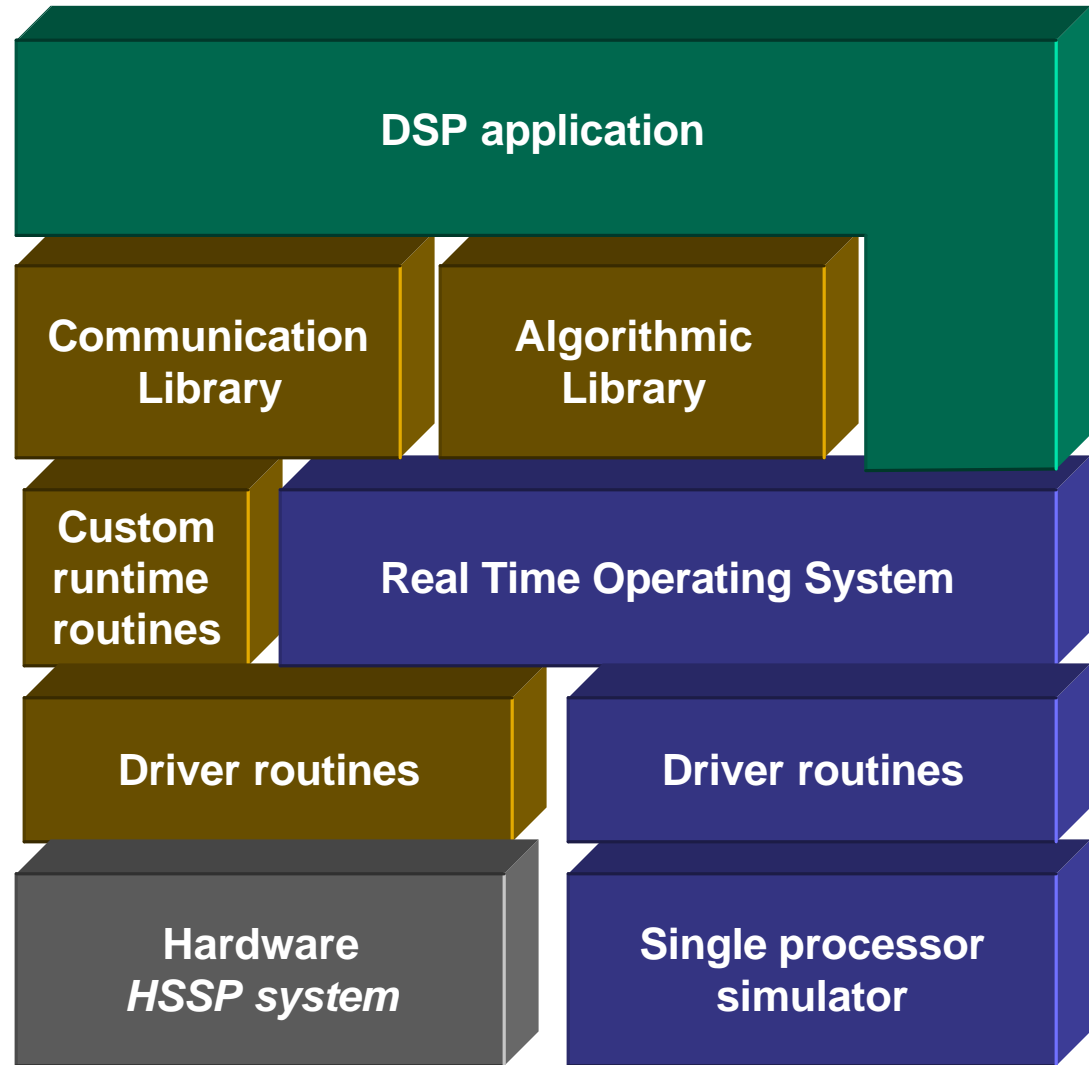

MIMD



## VLSI test implementation

- One processor array
- Clock and control distribution
- LSI Logics G12 process (0.18 mm), standard cell
- Total area 227 mm<sup>2</sup>
  - Clearly dominated by memories
  - Memory size can however be substantially decreased
- Control unit and processor elements capable of 335 and 396 MHz, respective
- Top level design capable of 210 MHz
- Control distribution a bottle neck, can however be pipelined

